

# PanelMAX 1010 Radiant Panel Heaters



# SOUTHEAST THERMAL SYSTEMS

WWW.SETHERMAL.COM

SALES@SEETHERMAL.COM

phone: 704-399-4248



## Technical Data:

- **Face Temperature:** 1000°F Maximum (595°C)
- **Wattage:** Watt densities up to 10 W/in<sup>2</sup> (1.5W/cm<sup>2</sup>)
- **Standard Dimensions:** ± 1/16 inch
- **Typical Peak Energy Wavelength:** 3.5-4 microns

Limitations			
Heater Dimensions	Min.	Max.	Increments
Width: inches (mm)	4 (101.6)	20 (508)	2 (50.8)
Length: inches (mm)	10 (254)	68 (1727.2)	any

Designed to resist contamination, the PanelMAX1010 is ideal for use in screen printing, food warming and other low heat applications. The heater's "sealed face" keeps contaminants away from the heating element, and this metal surface can be easily wiped or brushed clean whenever needed. The rugged all-metal construction results in a shock-proof shatter-proof heater that is durable and long lasting. No fragile glass, ceramic or fiber is used.

## Features & Benefits:

- **Uniform full surface heat** source provides better, more even heats.
- **No reflectors** to clean or replace.
- **Accurate, repeatable temperature** sensing options.
- **Convenient ready-to-use-package** makes installation easier.
- **One inch thick** backside insulation reduces losses.
- **UL® component recognized** versions are available
- **Totally sealed version available** suitable for hose down applications.

## Applications:

- Drying screen-printed textiles
- Curing process coatings on circuit boards
- Food warming/cooking
- Epoxy curing
- Thermoforming

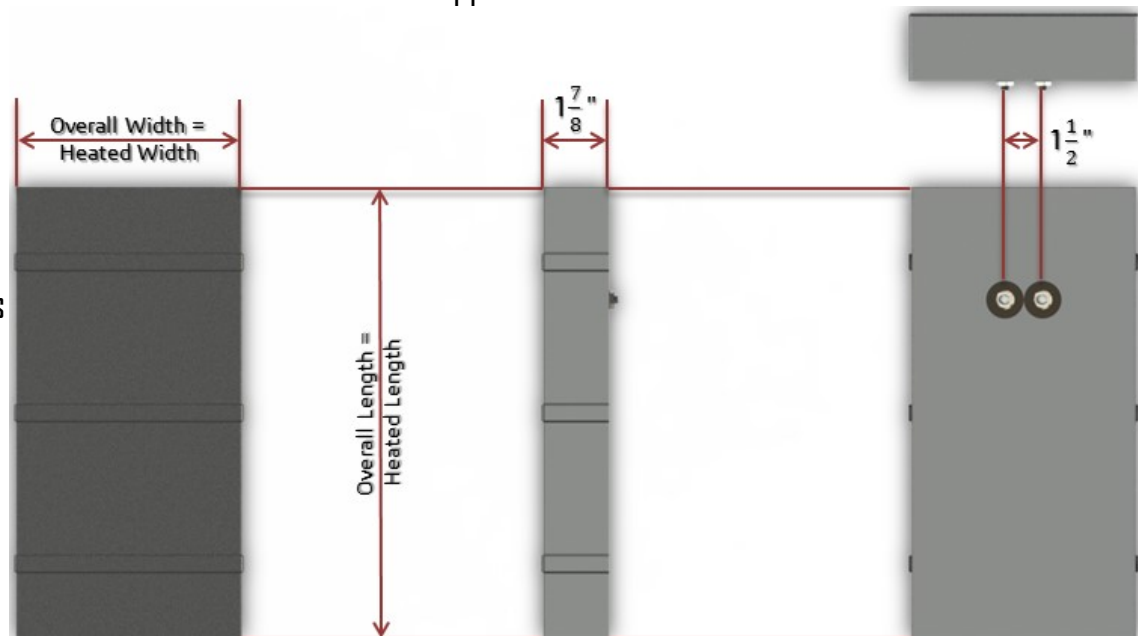

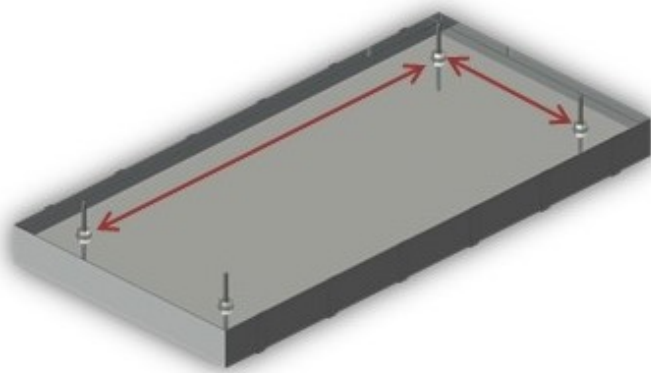

### **Mounting Studs**

Standard 1/4 X 20 X 1 1/2 inch (M6 X 40) steel studs are welded to the case. For best support, studs should be approximately located on 12 inch centers. Consult Watlow for exact locations on specific heaters.

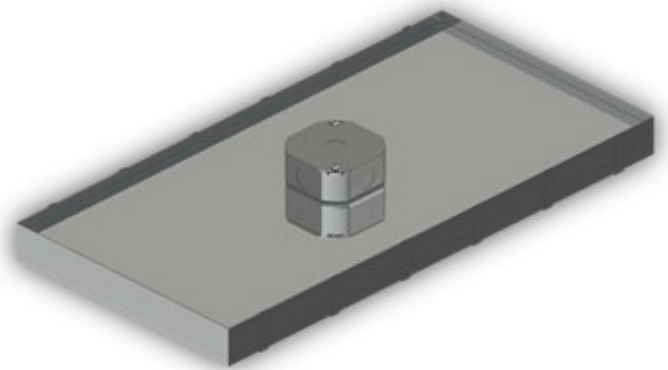

### **Terminal Box**

To protect electrical connections, a standard NEMA terminal box is available. The standard size is 4 X 4 X 1 5/8 inches (102 X 102 X 41 mm) with knockouts for 1/2 inch (12.5 mm) conduit. Other NEMA sizes are also available.

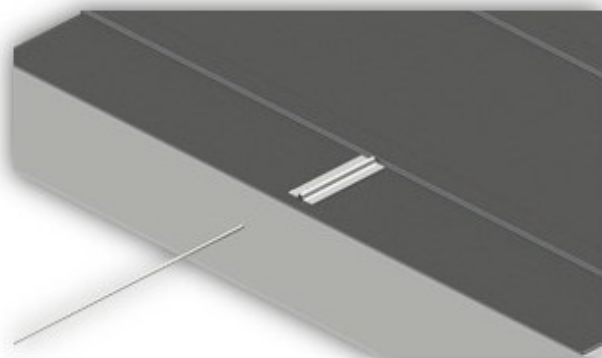

### **Thermocouple Pocket**

A thermocouple pocket is welded to the emitting surface. The pocket accepts a 0.063 inch (1.6 mm) diameter thermocouple (not included). This option provides accurate temperature sensing and easy thermocouple replacement.



### **Thermowell**

A thermowell allows you to use a thermocouple with a bayonet fitting to monitor heater temperature. The thermowell is located on the back of the panel to allow easy access for thermocouple replacement. Spring tension holds the tip of the thermocouple in contact for close control of the heater temperature. Thermocouple sold separately.