

THERMOWELL ASSEMBLIES & THERMOWELLS INDEX

	PAGE
General Information & Part Numbering Examples	T2
RTD & T/C Style Thermowell Assemblies	
RTD'S for Thermowells (RT, RV, R4, RW, R1, R2, R5, or R8)	T3
RTD'S with Thermowells (RT, RV, R4, RW, R1, R2, R5, or R8)	T4
Thermocouples for Thermowells (MT, MV, M4, MW, M1, M2, M5, or M8)	T5
Thermocouples with Thermowells (MT, MV, M4, MW, M1, M2, M5, or M8)	T6
Replacement RTD's for Thermowells (RC)	T7
Replacement Thermocouples for Thermowells (MC)	T8
Thermowells	
Standard Threaded Thermowells - Stepped Stem, .260" Bore (R)	T9
Standard Threaded Thermowells - Straight Stem, .260" Bore (S)	T10
Heavy Duty Threaded Thermowells - Tapered Stem, .260" Bore(H)	T11
Standard Threaded Thermowells - Straight Stem, .385" Bore (S)	T12
Heavy Duty Threaded Thermowells - Tapered Stem, .385" Bore (H)	T13
Standard Duty Flanged Thermowells - Straight Stem (FS)	T14
Heavy Duty Flanged Thermowells - Tapered Stem (FH)	T15
ANSI Flange Dimensions	T16

General Information

Thermowell Assemblies & Thermowells

SensorTec offers a complete line of thermocouple and RTD thermowell assemblies and thermowells. Whether you are looking for thermowell assemblies for a large industrial project or a few replacement units, SensorTec can meet your requirements.

Standard well materials are 304 stainless steel, 316 stainless steel, brass and carbon steel. Several custom well materials and configurations are available. Contact SensorTec for details.

Applications:

- Chemical and Petrochemical
- Oil refineries
- Power plants
- Water and sanitation treatment plants
- High pressure fluid lines
- Tanks

PART NUMBERING EXAMPLES FOR THERMOWELL ASSEMBLIES & THERMOWELLS

RTBGL-101W-R02-5-055-T

RTD-100Ω, 3 Wire, Class B, .00385, Low Temp, Hex Nipple Extension, 316 SST, Reduced tip thermowell, 1/2" NPT Process Connection, "U" Length (Insertion Depth) = 5 1/2", 304 SST

Refer to Page T-4 - RTD's with Thermowells

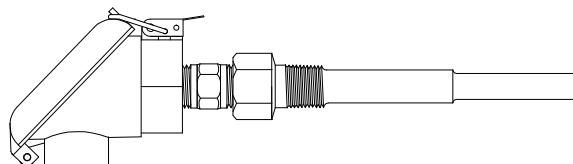

MTKOU-406T-K03A

MgO style T/C, Type "K", Single, Ungrounded, Union/Nipple/Union Extension, 304 SST, 1/4" OD Sheath Diameter, 6" of Sheath extending from extension. Refer to Page T-5 - Thermocouples for Thermowells

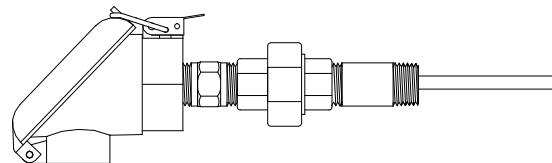

SL2-7-045-W

Straight stem thermowell, .260 ID Bore, 3/4" NPT Process Connection, 1/2" NPT Instrument Connection, "U" Length (Insertion Depth) = 4 1/2", 316 SST.

Refer to Page T-9 - T16 - Thermowells

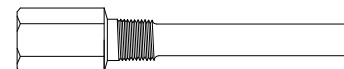

RTD'S for THERMOWELLS

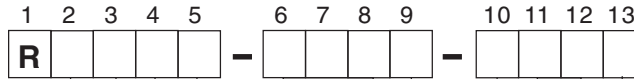
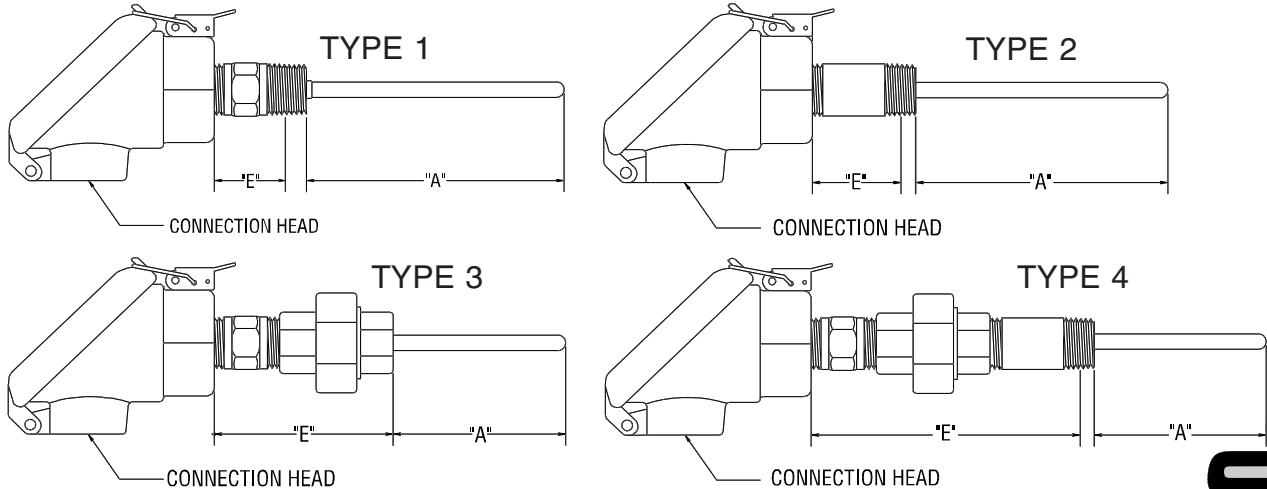

CONNECTION HEAD TYPE	
SNAP-COVER STYLES	
T = Cast Aluminum	
V = White Polypropylene	
4 = DIN "B" Size Aluminum	
SCREW-COVER STYLES	
W= Explosion Proof*	
1 = Cast Aluminum	
2 = Cast Iron	
5 = White Polypropylene	
8 = Stainless Steel (T-316)	

SHEATH LENGTH ("A" Fractional)	
A = None	J = 3/8"
C = 1/8"	L = 1/2"
E = 3/16"	Q = 3/4"
G = 1/4"	

SHEATH LENGTH ("A")	
Whole Inches: Example 04 = 4 Inches	

SHEATH DIAMETER (Inch)	
K = .250" (1/4")	
N = .375" (3/8")	

ELEMENT TYPE			
Resistance @ 0°C	2 Wire	3 Wire	4 Wire
Platinum 100Ω Single	A	B	C
Platinum 100Ω Dual	D	E	N/A
Platinum 500Ω Single	F	G	H
Platinum 1000Ω Single	K	L	M

EXTENSION MATERIAL	
	Code
Steel / Malleable Iron	D
304 Stainless Steel	T
316 Stainless Steel	W

ACCURACY & TEMPERATURE COEFFICIENT		
Accuracy @ 0°C	Din.00385	Jis.00392
Class B (.12%)	G	H
Class A (.06%)	J	K
1/3rd (.04%)	M	N
1/10th (.01%)	Q	N/A

CONFIGURATION**		Type	"E"- Extension Length (Inches)
Head with hex nipple		1	01
Head with pipe nipple only		2	02, 03, 04, 06
Head with hex nipple & union		3	03
Head with hex nipple/union/nipple		4	04, 05, 06

TEMPERATURE RANGE	
-50 to +200° C	L
-50 to +450° C	M
-200 to +650° C	H

**All are 1/2" NPT thread size and nominal length.

NOTES: All elements are spring loaded to ensure positive contact in the thermowell. Sheath material is 316 SST regardless of well material.

* Explosion Proof Head Meets the Following Location Classifications:



CLASS I, DIV I GROUPS B, C AND D
CLASS II, DIV I GROUPS E, F AND G
(316SST version also meets NEMA 4X or IP66)

* Ex Rating available upon request (Excd IIC ATEX II 2G)

RTD'S with THERMOWELLS

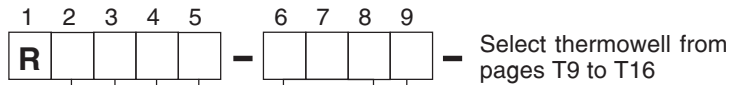
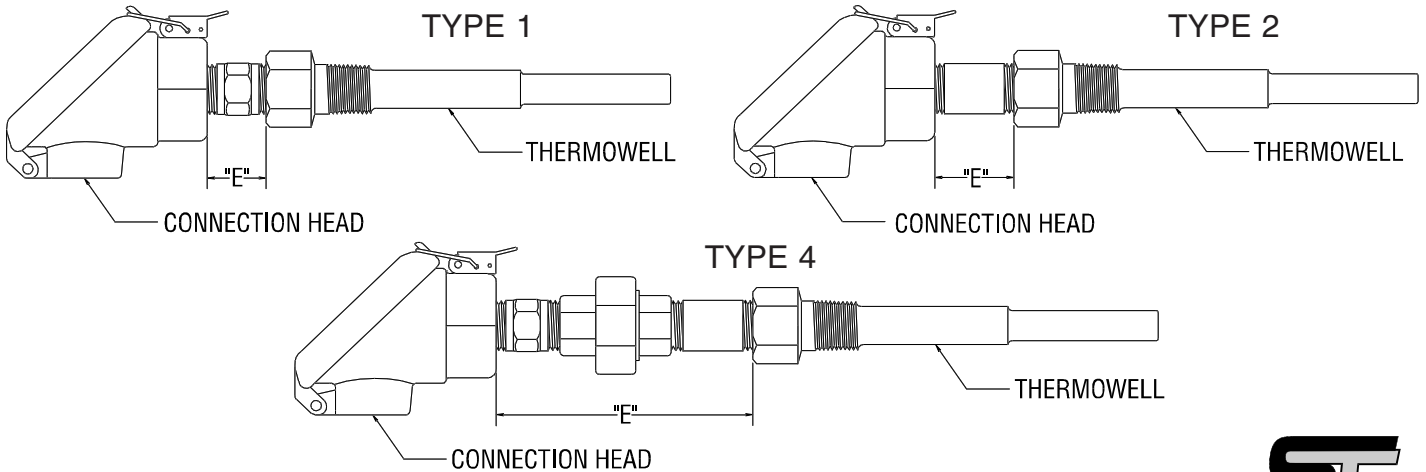

CONNECTION HEAD TYPE

SNAP-COVER STYLES

- T = Cast Aluminum
- V = White Polypropylene
- 4 = DIN "B" Size Aluminum

SCREW-COVER STYLES

- W = Explosion Proof*
- 1 = Cast Aluminum
- 2 = Cast Iron
- 5 = White Polypropylene
- 8 = Stainless Steel (T-316)

EXTENSION MATERIAL	Code
Steel / Malleable Iron	D
304 Stainless Steel	T
316 Stainless Steel	W

CONFIGURATION**	"E"- Extension Length (Inches)	
	Type	
Head with hex nipple	1	01
Head with pipe nipple only	2	02, 03, 04, 06
Head with hex nipple/union/nipple	4	04, 05, 06

**All are 1/2" NPT thread size and nominal length

ELEMENT TYPE

Resistance @ 0°C	2 Wire	3 Wire	4 Wire
Platinum 100Ω Single	A	B	C
Platinum 100Ω Dual	D	E	N/A
Platinum 500Ω Single	F	G	H
Platinum 1000Ω Single	K	L	M

ACCURACY & TEMPERATURE COEFFICIENT

Accuracy @ 0°C	Din.00385	Jis.00392
Class B (.12%)	G	H
Class A (.06%)	J	K
1/3rd (.04%)	M	N
1/10th (.01%)	Q	N/A

TEMPERATURE RANGE

-50 to +200° C	L
-50 to +450° C	M
-200 to +650° C	H

NOTES: All elements are spring loaded to ensure positive contact in the thermowell.
Sheath material is 316 SST regardless of well material.

Explosion Proof Head Meets the Following Location Classifications:

(316SST version also meets NEMA 4X or IP66)

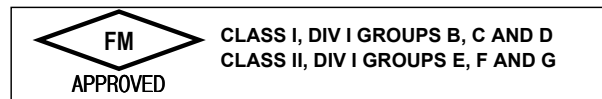

CLASS I, DIV I GROUPS B, C AND D
CLASS II, DIV I GROUPS E, F AND G

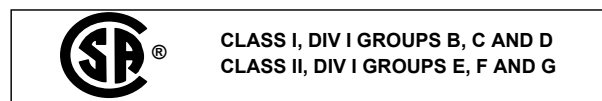

CLASS I, DIV I GROUPS B, C AND D
CLASS II, DIV I GROUPS E, F AND G

* Ex Rating available upon request



Eexd IIC ATEX II 2G

THERMOCOUPLES for THERMOWELLS

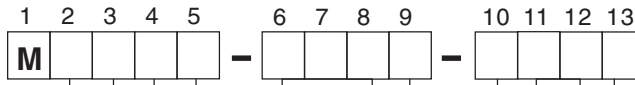
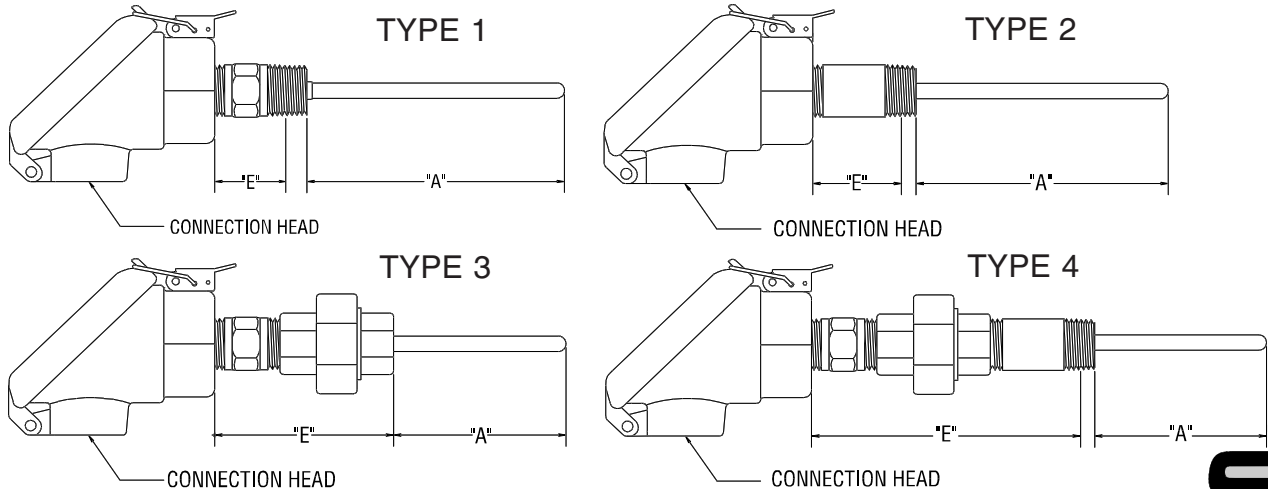

CONNECTION HEAD TYPE

SNAP-COVER STYLES

- T = Cast Aluminum
- V = Black Polypropylene
- 4 = DIN "B" Size Aluminum

SCREW-COVER STYLES

- W = Explosion Proof*
- 1 = Cast Aluminum
- 2 = Cast Iron
- 5 = White Polypropylene
- 8 = Stainless Steel (T-304)

CALIBRATION

- J = Type "J"
- K = Type "K"
- E = Type "E"
- T = Type "T"

TYPE/OPTION

- 0 = None (Single 2 Wire)
- 1 = Special Limits of Error
- 2 = High Purity (99.4%) Insulation
- 3 = Special Limits & High Purity
- 4 = Duplex Construction (4 Wire)
- 5 = Duplex Special Limits
- 6 = Duplex High Purity Insulation
- 7 = Duplex Special Limits & High Purity

JUNCTION TYPE

- E = Exposed
- G = Grounded
- U = Ungrounded

SHEATH LENGTH ("A" Fractional)

- A = None
- C = 1/8"
- E = 3/16"
- G = 1/4"
- J = 3/8"
- L = 1/2"
- Q = 3/4"

SHEATH LENGTH ("A")

Whole Inches: Example 04 = 4 Inches

SHEATH DIAMETER (Inch)

- K = .250" (1/4")
- N = .375" (3/8")

EXTENSION MATERIAL

Material	Code
Steel / Malleable Iron	D
304 Stainless Steel	T
316 Stainless Steel	W

CONFIGURATION**

Configuration	Type	"E"- Extension Length (Inches)
Head with hex nipple	1	01
Head with pipe nipple only	2	02, 03, 04, 06
Head with hex nipple & union	3	03
Head with hex nipple/union/nipple	4	04, 05, 06

**All are 1/2" NPT thread size and nominal length.

NOTES: All elements are spring loaded to ensure positive contact in the thermowell.
Sheath material is 316 SST regardless of well material.

* Explosion Proof Head Meets the Following Location Classifications:



CLASS I, DIV I GROUPS B, C AND D
CLASS II, DIV I GROUPS E, F AND G
(316SST version also meets NEMA 4X or IP66)

* Ex Rating available upon request (Eexd IIC ATEX II 2G)

THERMOCOUPLES with THERMOWELLS

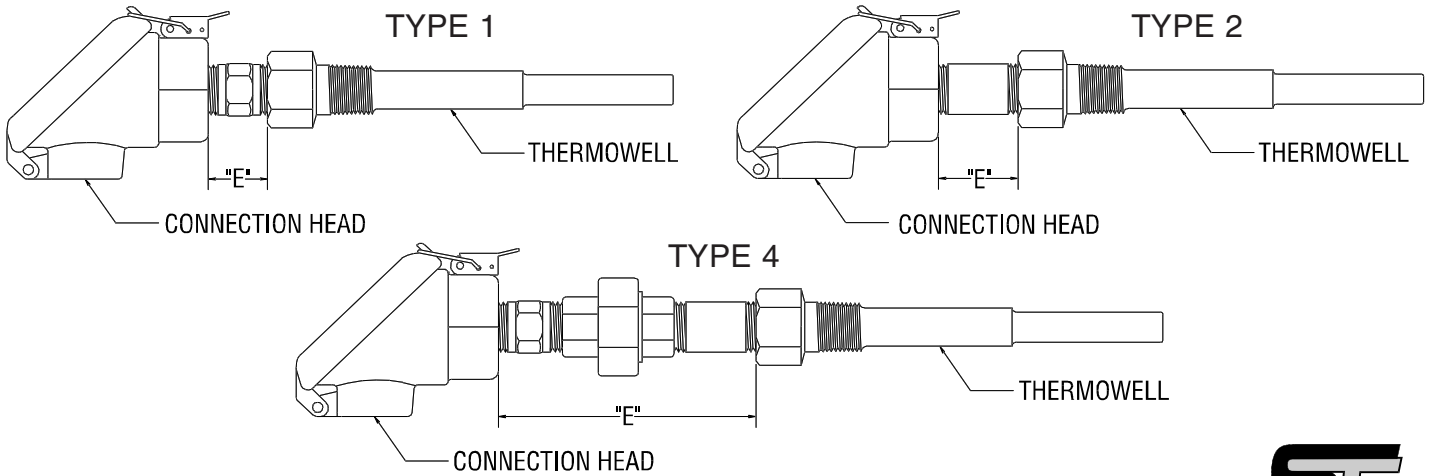

1 2 3 4 5 - 6 7 8 9 - Select thermowell from pages T9 to T16

CONNECTION HEAD TYPE

SNAP-COVER STYLES

- T = Cast Aluminum
- V = Black Polypropylene
- 4 = DIN "B" Size Aluminum

SCREW-COVER STYLES

- W = Explosion Proof*
- 1 = Cast Aluminum
- 2 = Cast Iron
- 5 = White Polypropylene
- 8 = Stainless Steel (T-304)

CALIBRATION

- J = Type "J"
- K = Type "K"
- E = Type "E"
- T = Type "T"

TYPE/OPTION

- 0 = None (Single 2 Wire)
- 1 = Special Limits of Error
- 2 = High Purity (99.4%) Insulation
- 3 = Special Limits & High Purity
- 4 = Duplex Construction (4 Wire)
- 5 = Duplex Special Limits
- 6 = Duplex High Purity Insulation
- 7 = Duplex Special Limits & High Purity

JUNCTION TYPE

- E = Exposed
- G = Grounded
- U = Ungrounded

EXTENSION MATERIAL

MATERIAL	Code
Steel / Malleable Iron	D
304 Stainless Steel	T
316 Stainless Steel	W

CONFIGURATION**

	"E"- Extension Length Code	
	Type	Code
Head with hex nipple (1" ext. only)	1	01
Head with pipe nipple only	2	02, 03, 04, 06
Head with hex nipple/union/nipple	4	04, 05, 06

**All are 1/2" NPT thread size and nominal length

NOTES: All elements are spring loaded to ensure positive contact in the thermowell.
Sheath material is 316 SST regardless of well material.

Explosion Proof Head Meets the Following Location Classifications:

(316SST version also meets NEMA 4X or IP66)



CLASS I, DIV I GROUPS B, C AND D
CLASS II, DIV I GROUPS E, F AND G



CLASS I, DIV I GROUPS B, C AND D
CLASS II, DIV I GROUPS E, F AND G

* Ex Rating available upon request



Eexd IIC ATEX II 2G

REPLACEMENT RTDS for THERMOWELLS

STYLE C

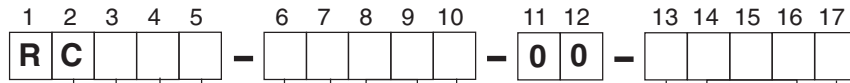
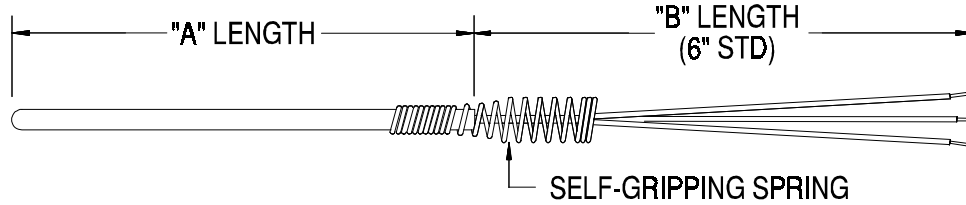

SHEATH TERMINATION

C = Spring Loaded Replacement Element for Thermowells

ELEMENT TYPE

Resistance @ 0°C	2 Wire	3 Wire	4 Wire
Platinum 100Ω Single	A	B	C
Platinum 100Ω Dual	D	E	N/A
Platinum 500Ω Single	F	G	H
Platinum 1000Ω Single	K	L	M

ACCURACY & TEMPERATURE COEFFICIENT

Accuracy @ 0°C	Din.00385	Jis.00392
Class B (.12%)	G	H
Class A (.06%)	J	K
1/3 RD (.04%)	M	N
1/10TH (.01%)	Q	N/A

TEMPERATURE RANGE

-50 to +200° C	L
-50 to +450° C	M
-200 to +650° C	H

SHEATH DIAMETER (Inch)

K = 1/4 (.250)
N = 3/8 (.375)

SHEATH MATERIAL

W = 316 SS

SHEATH LENGTH ("A")

Whole Inches: Example 00 = None

SHEATH LENGTH ("A" Fractional)

A = None	G = 1/4	N = 5/8
B = 1/16	J = 3/8	Q = 3/4
C = 1/8	L = 1/2	S = 7/8
E = 3/16		

LEADWIRE TERMINATIONS

A = None
B = Leads Stripped and Tinned

LEADWIRE LENGTH ("B")

Whole Inches: Example: 006 = 6 Inches

LEADWIRE TYPE

1 = Stranded Teflon Singles
9 = Stranded Fiberglass Singles

REPLACEMENT THERMOCOUPLES for THERMOWELLS

STYLE C

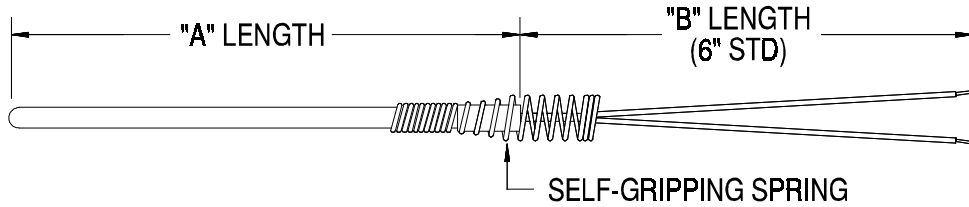

Note: "A" length is from tip of sensor to back of transition



1	2	3	4	5	6	7	8	9	10	11	12	13	14	15	16	17
M	C									0	0					

SHEATH TERMINATION
C = Spring Loaded Replacement Element for Thermowells

CALIBRATION
J = Type "J"
K = Type "K"
E = Type "E"
T = Type "T"

TYPE/OPTION
0 = None (Single 2 Wire)
1 = Special Limits of Error
2 = High Purity (99.4%) Insulation
3 = Special Limits & High Purity
4 = Duplex Construction (4 Wire)
5 = Duplex Special Limits
6 = Duplex High Purity Insulation
7 = Duplex Special Limits & High Purity

JUNCTION TYPE
G = Grounded, Round Tip
U = Ungrounded, Round Tip

SHEATH DIAMETER (Inch)
K = 1/4 (.250)
N = 3/8 (.375)

SHEATH MATERIAL
J = Inconel 600 V = 310 SS
S = 446 SS W = 316 SS
T = 304 SS

SHEATH LENGTH ("A")
Whole Inches: Example 12 = 12"

LEADWIRE TERMINATIONS
A = None
B = Leads Stripped and Tinned

LEADWIRE LENGTH ("B")
Whole Inches: Example: 006 = 6 Inches

LEADWIRE TYPE
1 = Stranded Teflon Singles
9 = Stranded Fiberglass Singles

SHEATH LENGTH ("A" Fractional)
A = None G = 1/4 N = 5/8
B = 1/16 J = 3/8 Q = 3/4
C = 1/8 L = 1/2 S = 7/8
E = 3/16

STANDARD THREADED THERMOWELLS

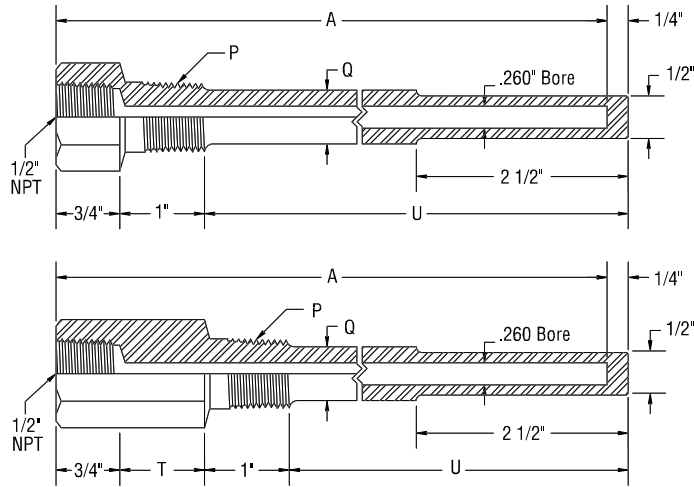

FOR 1/4" DIAMETER ELEMENTS - STEPPED STEM

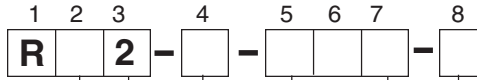

WELL LAG

0 = Non-lagging
L = Lagging

WELL BORE

2 = .260 Bore for 1/4" OD Elements

PROCESS CONNECTION

5 = 1/2" NPT Process Connection
7 = 3/4" NPT Process Connection
1 = 1" NPT Process Connection

WELL MATERIAL

A = Brass
D = C-1018 Carbon Steel
T = 304 SST
W = 316 SST

Consult sales for other materials and coating finishes

INSERTION LENGTH

By Half Inch Example 045 = 4 1/2"

EXTERNAL THREADED P	ORDER CODE	STEM LGTH. A	INSERT. LGTH. U	SHANK DIA. Q
1/2" NPT	R02-5-045	6	4 1/2	5/8
	R02-5-075	9	7 1/2	5/8
	R02-5-105	12	10 1/2	5/8
	R02-5-135	15	13 1/2	5/8
	R02-5-165	18	16 1/2	5/8
	R02-5-225	24	22 1/2	5/8
3/4" NPT	R02-7-045	6	4 1/2	3/4
	R02-7-075	9	7 1/2	3/4
	R02-7-105	12	10 1/2	3/4
	R02-7-135	15	13 1/2	3/4
	R02-7-165	18	16 1/2	3/4
	R02-7-225	24	22 1/2	3/4
1" NPT	R02-1-045	6	4 1/2	7/8
	R02-1-075	9	7 1/2	7/8
	R02-1-105	12	10 1/2	7/8
	R02-1-135	15	13 1/2	7/8
	R02-1-165	18	16 1/2	7/8
	R02-1-225	24	22 1/2	7/8

EXTERNAL THREADED P	ORDER CODE	STEM LGTH. A	INSERT. LGTH. U	LAG EXT. T	SHANK DIA. Q
1/2" NPT	RL2-5-045	9	4 1/2	3	5/8
	RL2-5-075	12	7 1/2	3	5/8
	RL2-5-105	15	10 1/2	3	5/8
	RL2-5-135	18	13 1/2	3	5/8
	RL2-5-195	24	19 1/2	3	5/8
3/4" NPT	RL2-7-045	9	4 1/2	3	3/4
	RL2-7-075	12	7 1/2	3	3/4
	RL2-7-105	15	10 1/2	3	3/4
	RL2-7-135	18	13 1/2	3	3/4
	RL2-7-195	24	19 1/2	3	3/4
1" NPT	RL2-1-045	9	4 1/2	3	7/8
	RL2-1-075	12	7 1/2	3	7/8
	RL2-1-105	15	10 1/2	3	7/8
	RL2-1-135	18	13 1/2	3	7/8

STANDARD THREADED THERMOWELLS

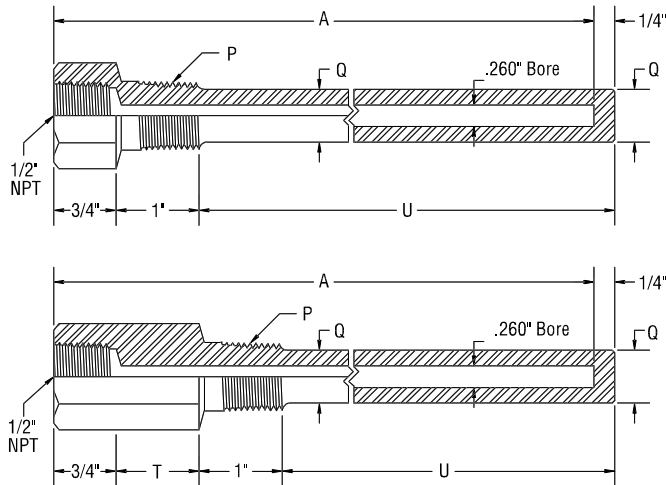

FOR 1/4" DIAMETER ELEMENTS - STRAIGHT STEM

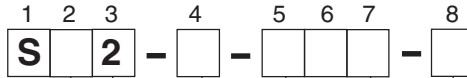

WELL LAG

0 = Non-lagging
L = Lagging

WELL BORE

2 = .260 Bore for 1/4" OD Elements

PROCESS CONNECTION

5 = 1/2" NPT Process Connection
7 = 3/4" NPT Process Connection
1 = 1" NPT Process Connection

WELL MATERIAL

A = Brass
D = C-1018 Carbon Steel
T = 304 SST
W = 316 SST

Consult sales for other materials and coating finishes

INSERTION LENGTH

By Half Inch Example 045 = 4 1/2"

EXTERNAL THREADED P	ORDER CODE	STEM LGTH. A	INSERT. LGTH. U	SHANK DIA. Q
1/2" NPT	S02-5-025	4	2 1/2	1/2
	S02-5-045	6	4 1/2	5/8
	S02-5-075	9	7 1/2	5/8
	S02-5-105	12	10 1/2	5/8
	S02-5-135	15	13 1/2	5/8
	S02-5-165	18	16 1/2	5/8
3/4" NPT	S02-5-225	24	22 1/2	5/8
	S02-7-025	4	2 1/2	1/2
	S02-7-045	6	4 1/2	3/4
	S02-7-075	9	7 1/2	3/4
	S02-7-105	12	10 1/2	3/4
	S02-7-135	15	13 1/2	3/4
1" NPT	S02-7-165	18	16 1/2	3/4
	S02-7-225	24	22 1/2	3/4
	S02-1-025	4	2 1/2	3/4
	S02-1-045	6	4 1/2	7/8
	S02-1-075	9	7 1/2	7/8
	S02-1-105	12	10 1/2	7/8
1" NPT	S02-1-135	15	13 1/2	7/8
	S02-1-165	18	16 1/2	7/8
	S02-1-225	24	22 1/2	7/8

EXTERNAL THREADED P	ORDER CODE	STEM LGTH. A	INSERT. LGTH. U	LAG EXT. T	SHANK DIA. Q
1/2" NPT	SL2-5-025	6	2 1/2	2	1/2
	SL2-5-045	9	4 1/2	3	5/8
	SL2-5-075	12	7 1/2	3	5/8
	SL2-5-105	15	10 1/2	3	5/8
	SL2-5-135	18	13 1/2	3	5/8
	SL2-5-195	24	19 1/2	3	5/8
3/4" NPT	SL2-7-025	6	2 1/2	2	1/2
	SL2-7-045	9	4 1/2	3	3/4
	SL2-7-075	12	7 1/2	3	3/4
	SL2-7-105	15	10 1/2	3	3/4
	SL2-7-135	18	13 1/2	3	3/4
	SL2-7-195	24	19 1/2	3	3/4
1" NPT	SL2-1-025	6	2 1/2	2	3/4
	SL2-1-045	9	4 1/2	3	7/8
	SL2-1-075	12	7 1/2	3	7/8
	SL2-1-105	15	10 1/2	3	7/8
	SL2-1-135	18	13 1/2	3	7/8
SL2-1-195	24	19 1/2	3	7/8	

HEAVY DUTY THREADED THERMOWELLS

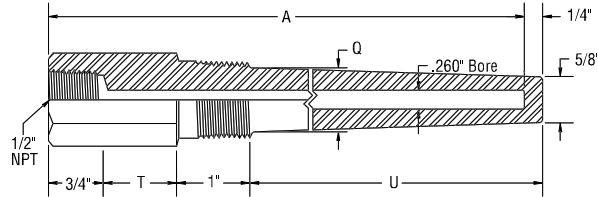
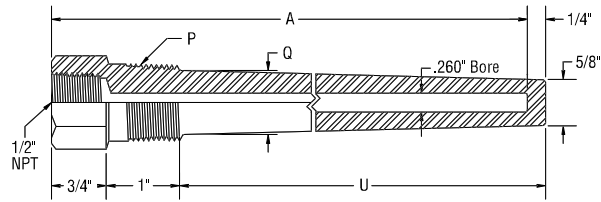

FOR 1/4" DIAMETER ELEMENTS - TAPERED STEM

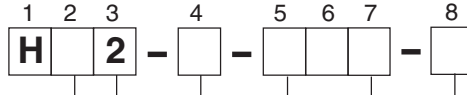

WELL LAG

- 0 = Non-lagging
- L = Lagging

WELL BORE

- 2 = .260 Bore for 1/4" OD Elements

PROCESS CONNECTION

- 5 = 1/2" NPT Process Connection
- 7 = 3/4" NPT Process Connection
- 1 = 1" NPT Process Connection

WELL MATERIAL

- A = Brass
- D = C-1018 Carbon Steel
- T = 304 SST
- W = 316 SST

Consult sales for other materials and coating finishes

INSERTION LENGTH

By Half Inch Example 045 = 4 1/2"

EXTERNAL THREADED P	ORDER CODE	STEM LGTH. A	INSERT. LGTH. U	SHANK DIA. Q
3/4" NPT	H02-7-025	4	2 1/2	7/8
	H02-7-045	6	4 1/2	7/8
	H02-7-075	9	7 1/2	7/8
	H02-7-105	12	10 1/2	7/8
	H02-7-135	15	13 1/2	7/8
	H02-7-165	18	16 1/2	7/8
	H02-7-225	24	22 1/2	7/8
1" NPT	H02-1-025	4	2 1/2	1-1/16
	H02-1-045	6	4 1/2	1-1/16
	H02-1-075	9	7 1/2	1-1/16
	H02-1-105	12	10 1/2	1-1/16
	H02-1-135	15	13 1/2	1-1/16
	H02-1-165	18	16 1/2	1-1/16
	H02-1-225	24	22 1/2	1-1/16

EXTERNAL THREADED P	ORDER CODE	STEM LGTH. A	INSERT. LGTH. U	LAG EXT. T	SHANK DIA. Q
3/4" NPT	HL2-7-025	6	2 1/2	2	7/8
	HL2-7-045	9	4 1/2	3	7/8
	HL2-7-075	12	7 1/2	3	7/8
	HL2-7-105	15	10 1/2	3	7/8
	HL2-7-135	18	13 1/2	3	7/8
	HL2-7-195	24	19 1/2	3	7/8
1" NPT	HL2-1-025	6	2 1/2	2	1-1/16
	HL2-1-045	9	4 1/2	3	1-1/16
	HL2-1-075	12	7 1/2	3	1-1/16
	HL2-1-105	15	10 1/2	3	1-1/16
	HL2-1-135	18	13 1/2	3	1-1/16
	HL2-1-195	24	19 1/2	3	1-1/16

STANDARD THREADED THERMOWELLS

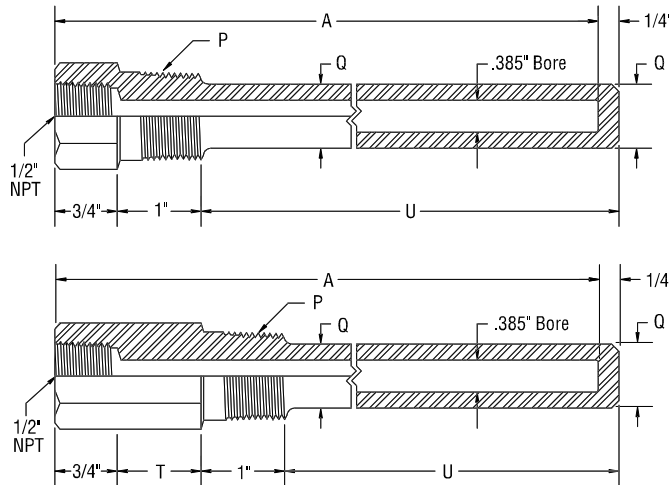

FOR 3/8" DIAMETER ELEMENTS - STRAIGHT STEM

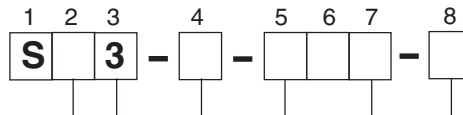

WELL LAG

0 = Non-lagging
L = Lagging

WELL BORE

3 = .390 Bore for 3/8" OD Elements

PROCESS CONNECTION

5 = 1/2" NPT Process Connection
7 = 3/4" NPT Process Connection
1 = 1" NPT Process Connection

WELL MATERIAL

A = Brass
D = C-1018 Carbon Steel
T = 304 SST
W = 316 SST

Consult sales for other materials and coating finishes

INSERTION LENGTH

By Half Inch Example 045 = 4 1/2"

EXTERNAL THREADED P	ORDER CODE	STEM LGTH. A	INSERT. LGTH. U	SHANK DIA. Q
3/4" NPT	S03-7-025	4	2 1/2	49/64
	S03-7-045	6	4 1/2	49/64
	S03-7-075	9	7 1/2	49/64
	S03-7-105	12	10 1/2	49/64
	S03-7-135	15	13 1/2	49/64
	S03-7-165	18	16 1/2	49/64
	S03-7-225	24	22 1/2	49/64
1" NPT	S03-1-025	4	2 1/2	7/8
	S03-1-045	6	4 1/2	7/8
	S03-1-075	9	7 1/2	7/8
	S03-1-105	12	10 1/2	7/8
	S03-1-135	15	13 1/2	7/8
	S03-1-165	18	16 1/2	7/8
	S03-1-225	24	22 1/2	7/8

EXTERNAL THREADED P	ORDER CODE	STEM LGTH. A	INSERT. LGTH. U	LAG EXT. T	SHANK DIA. Q
3/4" NPT	SL3-7-025	6	2 1/2	2	49/64
	SL3-7-045	9	4 1/2	3	49/64
	SL3-7-075	12	7 1/2	3	49/64
	SL3-7-105	15	10 1/2	3	49/64
	SL3-7-135	18	13 1/2	3	49/64
	SL3-7-195	24	19 1/2	3	49/64
	1" NPT	SL3-1-025	6	2 1/2	2
SL3-1-045		9	4 1/2	3	7/8
SL3-1-075		12	7 1/2	3	7/8
SL3-1-105		15	10 1/2	3	7/8
SL3-1-135		18	13 1/2	3	7/8
SL3-1-195		24	19 1/2	3	7/8

HEAVY DUTY THREADED THERMOWELLS

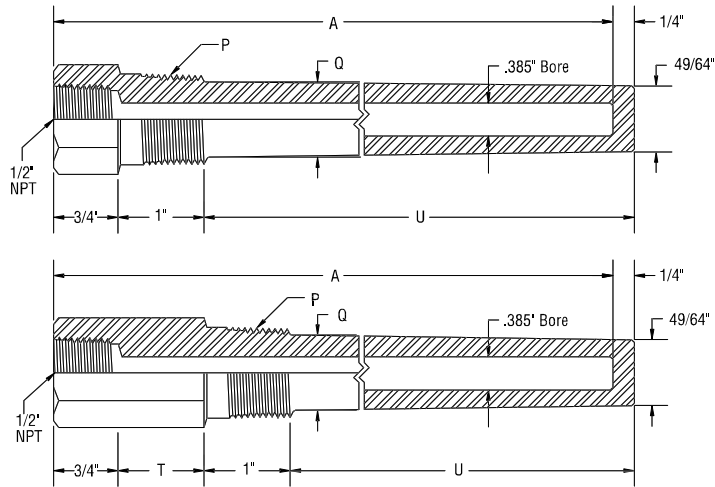

FOR 3/8" DIAMETER ELEMENTS - TAPERED STEM

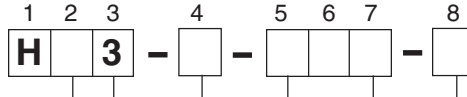

WELL LAG

0 = Non-lagging
L = Lagging

WELL BORE

3 = .390 Bore for 3/8" OD Elements

PROCESS CONNECTION

5 = 1/2" NPT Process Connection
7 = 3/4" NPT Process Connection
1 = 1" NPT Process Connection

WELL MATERIAL

A = Brass
D = C-1018 Carbon Steel
T = 304 SST
W = 316 SST

Consult sales for other materials and coating finishes

INSERTION LENGTH

By Half Inch Example 045 = 4 1/2"

EXTERNAL THREADED P	ORDER CODE	STEM LGTH. A	INSERT. LGTH. U	SHANK DIA. Q
3/4" NPT	H03-7-025	4	2 1/2	7/8
	H03-7-045	6	4 1/2	7/8
	H03-7-075	9	7 1/2	7/8
	H03-7-105	12	10 1/2	7/8
	H03-7-135	15	13 1/2	7/8
	H03-7-165	18	16 1/2	7/8
	H03-7-225	24	22 1/2	7/8
1" NPT	H03-1-025	4	2 1/2	1-1/16
	H03-1-045	6	4 1/2	1-1/16
	H03-1-075	9	7 1/2	1-1/16
	H03-1-105	12	10 1/2	1-1/16
	H03-1-135	15	13 1/2	1-1/16
	H03-1-165	18	16 1/2	1-1/16
	H03-1-225	24	22 1/2	1-1/16

EXTERNAL THREADED P	ORDER CODE	STEM LGTH. A	INSERT. LGTH. U	LAG EXT. T	SHANK DIA. Q
3/4" NPT	HL3-7-025	6	2 1/2	2	7/8
	HL3-7-045	9	4 1/2	3	7/8
	HL3-7-075	12	7 1/2	3	7/8
	HL3-7-105	15	10 1/2	3	7/8
	HL3-7-135	18	13 1/2	3	7/8
	HL3-7-195	24	19 1/2	3	7/8
1" NPT	HL3-1-025	6	2 1/2	2	1-1/16
	HL3-1-045	9	4 1/2	3	1-1/16
	HL3-1-075	12	7 1/2	3	1-1/16
	HL3-1-105	15	10 1/2	3	1-1/16
	HL3-1-135	18	13 1/2	3	1-1/16
	HL3-1-195	24	19 1/2	3	1-1/16

STANDARD DUTY FLANGED THERMOWELLS

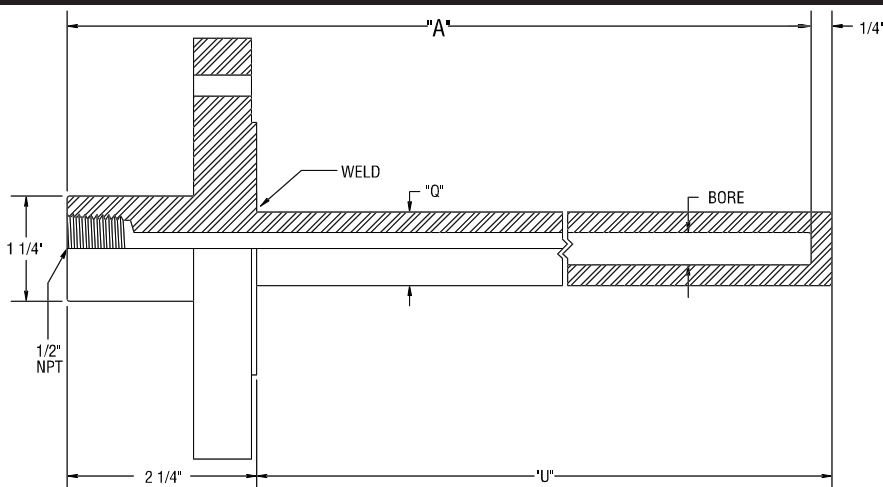

FOR 1/4" AND 3/8" DIAMETER ELEMENTS

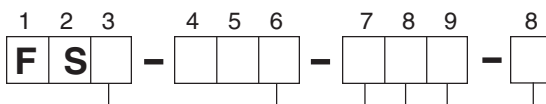

1/4" Elements (.260" bore)

ORDER CODE	ELEM LGTH. A	INSERT. LGTH. U	SHANK DIA. Q
FS2-020	4	2	3/4
FS2-040	6	4	3/4
FS2-070	9	7	3/4
FS2-100	12	10	3/4
FS2-130	15	13	3/4
FS2-160	18	16	3/4
FS2-220	24	22	3/4

3/8" Elements (.390" bore)

ORDER CODE	ELEM LGTH. A	INSERT. LGTH. U	SHANK DIA. Q
FS3-020	4	2	7/8
FS3-040	6	4	7/8
FS3-070	9	7	7/8
FS3-100	12	10	7/8
FS3-130	15	13	7/8
FS3-160	18	16	7/8
FS3-220	24	22	7/8

WELL MATERIAL

A = Brass
 D = C-1018 Carbon Steel
 T = 304 SST
 W = 316 SST

Consult sales for other materials and coating finishes

Code	Flange Type
R	Raised Face
F	Flat Face
J	Ring Joint

Code	Rating (lbs.)
1	150
2	300
3	600
4	900
5	1500
6	2500

Code	Flange Size (Inch)
A	3/4
B	1
C	1 1/2
D	2
E	3

HEAVY DUTY FLANGED THERMOWELLS

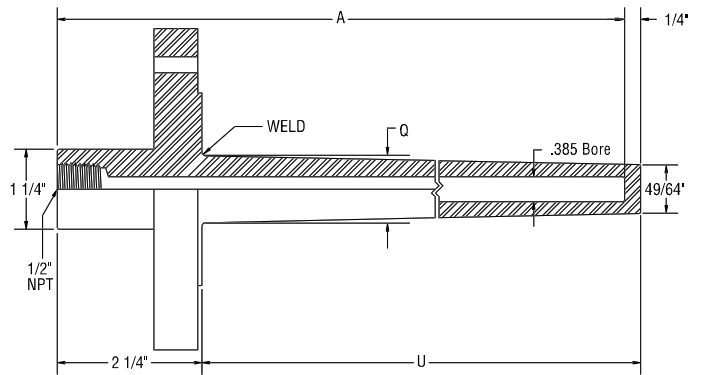
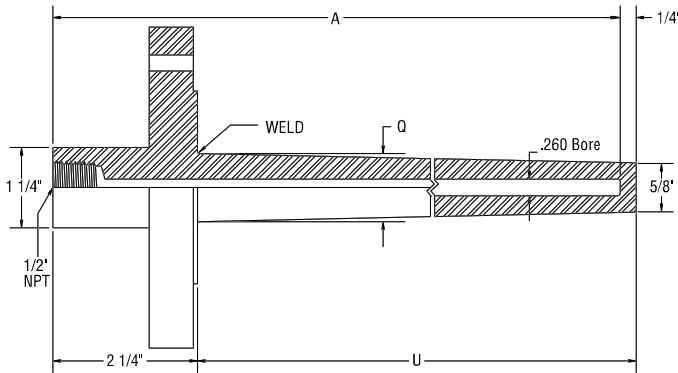

FOR 1/4" AND 3/8" DIAMETER ELEMENTS

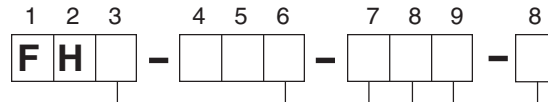

1/4" Elements (.260" bore)

ORDER CODE	ELEM LGTH. A	INSERT. LGTH. U	SHANK DIA. Q
FH2-020	4	2	1" flange & smaller Q=7/8"
FH2-040	6	4	
FH2-070	9	7	
FH2-100	12	10	1-1/2" flange & larger Q=1-1/16"
FH2-130	15	13	
FH2-160	18	16	
FH2-220	24	22	

3/8" Elements (.390" bore)

ORDER CODE	ELEM LGTH. A	INSERT. LGTH. U	SHANK DIA. Q
FH3-020	4	2	1" flange & smaller Q=7/8"
FH3-040	6	4	
FH3-070	9	7	
FH3-100	12	10	1-1/2" flange & larger Q=1-1/16"
FH3-130	15	13	
FH3-160	18	16	
FH3-220	24	22	

WELL MATERIAL

A = Brass
D = C-1018 Carbon Steel
T = 304 SST
W = 316 SST

Consult sales for other materials and coating finishes

Code	Rating (lbs.)
R	Raised Face
F	Flat Face
J	Ring Joint

Code	Rating (lbs.)
1	150
2	300
3	600
4	900
5	1500
6	2500

Code	Flange Size (Inch)
A	3/4
B	1
C	1 1/2
D	2
E	3

ANSI FLANGE DIMENSIONS

150 lb. STANDARD

Nom. Pipe Size	Outside Diam. Flange	Flange Thickness	Drill Template		
			No. Holes	Diam. Bolts	Bolt Circle
1/2	3-1/2	7/16	4	1/2	2-3/8
3/4	3-7/8	1/2	4	1/2	2-3/4
1	4-1/4	9/16	4	1/2	3-1/8
1-1/4	4-5/8	5/8	4	1/2	3-1/2
1-1/2	5	11/16	4	1/2	3-7/8
2	6	3/4	4	5/8	4-3/4
2-1/2	7	7/8	4	5/8	5-1/2
3	7-1/2	15/16	4	5/8	6
3-1/2	8-1/2	15/16	8	5/8	7
4	9	15/16	8	5/8	7-1/2
5	10	15/16	8	3/4	8-1/2
6	11	1	8	3/4	9-1/2
8	13-1/2	1-1/8	8	3/4	11-3/4
10	16	1-3/16	12	7/8	14-1/4
12	19	1-1/4	12	7/8	17

300 lb. STANDARD

Nom. Pipe Size	Outside Diam. Flange	Flange Thickness	Drill Template		
			No. Holes	Diam. Bolts	Bolt Circle
1/2	3-3/4	9/16	4	1/2	2-5/8
3/4	4-5/8	5/8	4	5/8	3-1/4
1	4-7/8	11/16	4	5/8	3-1/2
1-1/4	5-1/4	3/4	4	5/8	3-7/8
1-1/2	6-1/8	13/16	4	3/4	4-1/2
2	6-1/2	7/8	8	5/8	5
2-1/2	7-1/2	1	8	3/4	5-7/8
3	8-1/4	1-1/8	8	3/4	6-5/8
3-1/2	9	1-3/16	8	3/4	7-1/4
4	10	1-1/4	8	3/4	7-7/8
5	11	1-3/8	8	3/4	9-1/4
6	12-1/2	1-7/16	12	3/4	10-5/8
8	15	1-5/8	12	7/8	13
10	17-1/2	1-7/8	16	1	15-1/4
12	20-1/2	2	16	1-1/8	17-3/4

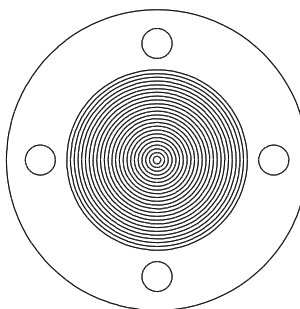

600 lb. STANDARD

Nom. Pipe Size	Outside Diam. Flange	Flange Thickness	Drill Template		
			No. Holes	Diam. Bolts	Bolt Circle
1/2	3-3/4	9/16	4	5/8	2-5/8
3/4	4-5/8	5/8	4	3/4	3-1/4
1	4-7/8	11/16	4	3/4	3-1/2
1-1/4	5-1/4	13/16	4	3/4	3-7/8
1-1/2	6-1/8	7/8	4	7/8	4-1/2
2	6-1/2	1	8	3/4	5
2-1/2	7-1/2	1-1/8	8	7/8	5-7/8
3	8-1/4	1-1/4	8	7/8	6-5/8
3-1/2	9	1-3/8	8	1	7-1/4
4	10-7/5	1-1/2	8	1	8-1/2
5	13	1-3/4	8	1-1/8	10-1/2
6	14	1-7/8	12	1-1/8	11-1/2
8	16-1/2	2-3/16	12	1-1/4	13-3/4
10	20	2-1/2	16	1-3/8	17
12	22	2-5/8	20	1-3/8	19-1/4

900 lb. STANDARD

Nom. Pipe Size	Outside Diam. Flange	Flange Thickness	Drill Template		
			No. Holes	Diam. Bolts	Bolt Circle
1/2	4-3/4	7/8	4	7/8	3-1/4
3/4	5-1/8	1	4	7/8	3-1/2
1	5-7/8	1-1/8	4	1	4
1-1/4	6-1/4	1-1/8	4	1	4-3/8
1-1/2	7	1-1/4	4	1-1/8	4-7/8
2	8-1/2	1-1/2	8	1	6-1/2
2-1/2	9-5/8	1-5/8	8	1-1/8	7-1/2
3	9-1/2	1-1/2	8	1	7-1/2
4	11-1/2	1-3/4	8	1-1/4	9-1/4
5	13-3/4	2	8	1-3/8	11
6	15	2-3/16	12	1-1/4	12-1/2
8	18-1/2	2-1/2	12	1-1/2	15-1/2
10	21-1/2	2-3/4	16	1-1/2	18-1/2
12	24	3-1/8	20	1-1/2	21