

INDICATOR

AG500

Digital Indicator



Green
RoHS
compliant

RKC RKC INSTRUMENT INC.

Digital Indicator AG500



High grade indicator has been redesigned for better visibility and more functions.

Resolution 1/100°C is available (RTD input)

Bright, Easy-To-Read LED Displays

Very clear and easy-to-read large LED display. Brightness has been increased to the double of RKC's conventional Digital Indicator REX-AD410.

Alarm status can be checked at a glance with alternate display of alarm characters.

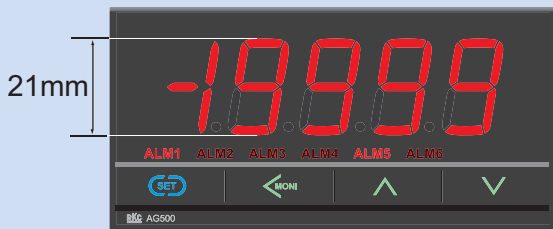

- Alarm character and PV alternate display at the time of alarm state.

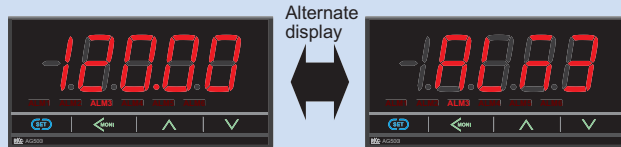

(when alarm 3 is in alarm state)

- Alternate display can be independently selected at each alarm (1 to 6).

Panel space saving : 60mm

The AG500 has very short depth as a 1/8 DIN size indicator.

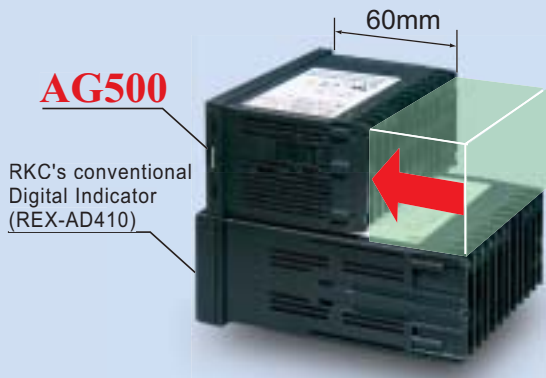

Numerous Input and Outputs (Optional)

Incorporates the following features on the same hardware:

- Contact input (max. 2 points)
- Alarm output (max. 6 points)
- Analog retransmission output
- Communication

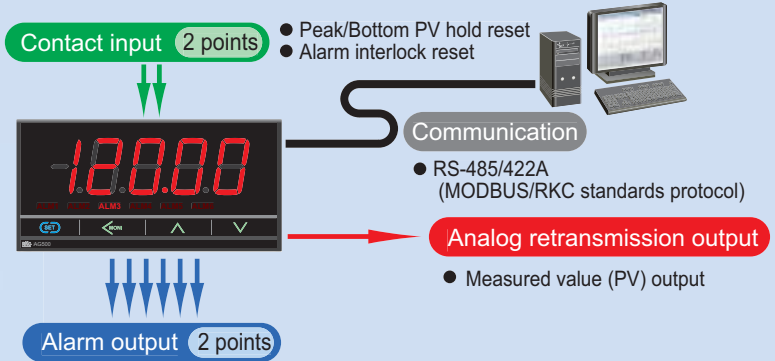

12/24V DC Sensor power supply (Optional)

Available with sensor power supply. Supply voltage can be specified from 12Vdc or 24Vdc.

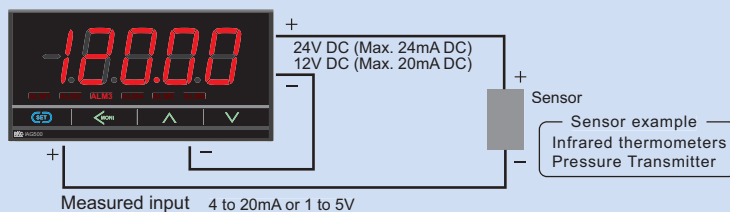

- When 24V DC sensor power supply is used, alarm output is max. 5 points.
- When 12V DC sensor power supply/LED drive supply for SP500 is used, alarm output is max. 5 points.

Standard Function

Alarm function

Interlock (Latch) Function

This function retains the alarm status until the interlock is reset, via front panel operation or communication.

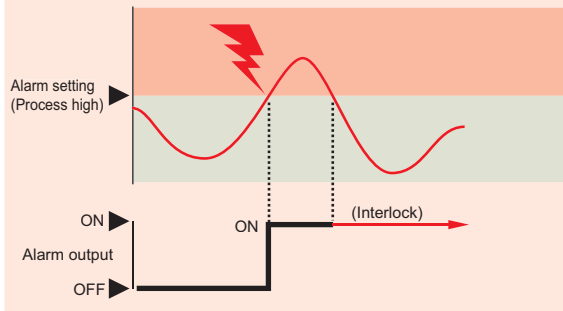

Alarm delay timer

When an alarm condition becomes ON status, the output is suppressed until the Delay Timer set time elapses. After the time is up, if the alarm output is still ON status, the output will be produced.

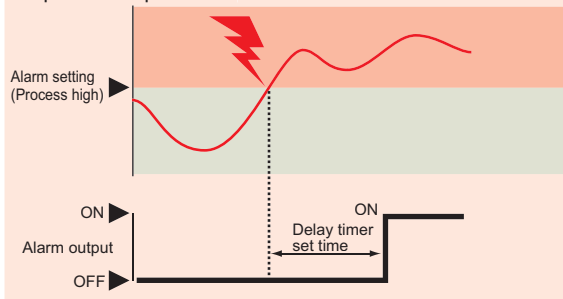

Hold action

Hold action is an action which makes an alarm function invalid even if measured value (PV) is in an alarm status at the time of power-ON. This state continues until the above measured-value (PV) once exits from an alarm status.

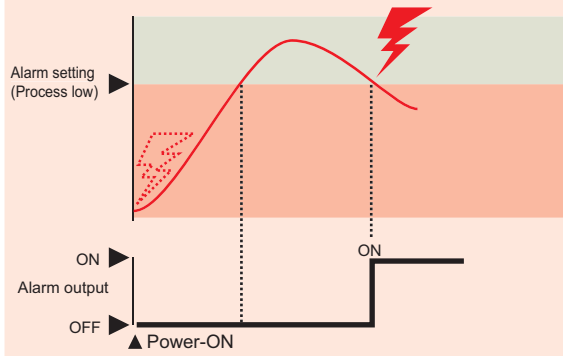

Alarm energized/de-energized action selection

● Energized action

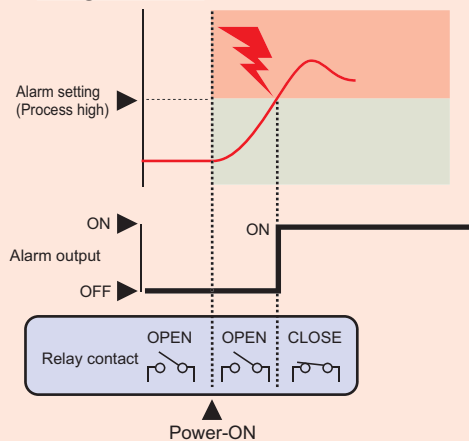

● De-energized action

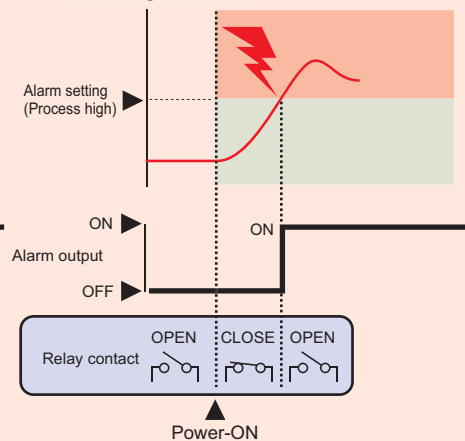

Display function

Peak and Bottom Hold Function

The AG500 memorizes the maximum and minimum measured value. Optional contact input enables you to remotely reset the value.

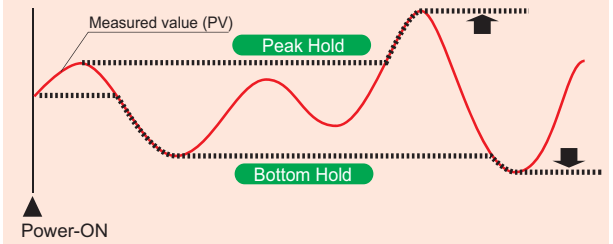

PV Bias and PV Ratio

PV bias adds bias to the measured value (PV). The PV bias is used to compensate the individual variations of the sensors or correct the difference between the measured value (PV) of other instruments. PV ratio is a multiplier to be applied to the measured value (PV). The PV ratio is used to compensate the individual variations of the sensors or correct the difference between the measured value (PV) of other instruments.

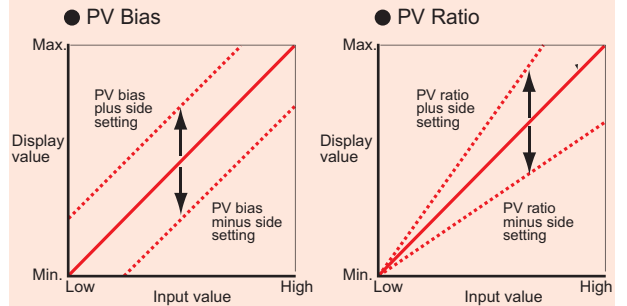

PV bias and PV ratio is available simultaneously..

Specifications

Input

Input	• Universal input (See Input range Code Table)
Measuring accuracy	a) Thermocouple Type : K, J, T, E, PLII, U, L Less than -100°C (-148°F) : ±1.0°C (±1.8°F) -100 to +500°C (-148 to 932°F) : ±0.5°C (±0.9°F) More than 500°C (932°F) : ±(0.1% of reading + 1 digit) Type : N, S, R, W5Re/W26Re Less than 0°C (32°F) : ±2.0°C (±3.6°F) 0 to 1000°C (32 to 1832°F) : ±1.0°C (±1.8°F) More than 1000°C (1832°F) : ±(0.1% of reading + 1 digit) Type B Less than 400°C (752°F) : ±70.0°C (±126°F) 400 to 1000°C (752 to 1832°F) : ±1.0°C (±1.8°F) More than 1000°C (1832°F) : ±(0.1% of reading + 1 digit) • Cold junction temperature compensation error ±1.0°C (1.8°F) [Between 5 and 40°C (41 and 104°F)] ±1.5°C (2.7°F) [Between -10 and 5°C (16 and 41°F), and 40 and 50°C (104 and 122°F)]
	b) RTD Less than 200°C (392°F) : ±0.2°C (±0.4°F) More than 200°C (392°F) : ±(0.1% of reading + 1 digit)
	c) DC voltage and DC current ±(0.1% of span)
Sampling time	0.1sec
Input impedance	a) Temperature, Low voltage input group : More than 1MΩ b) High voltage input group : Approx 1MΩ c) Current Input : 50Ω
Sensor current	Approx 250μA (RTD input):
Influence of external resistance	0.2μV/Ω (Thermocouple input)
Influence of lead resistance	0.01% of reading/Ω (RTD input)
Input break action	• Maximum 10Ω per wire Thermocouple input : Up-scale/Down-scale (Selectable) RTD input : Up-scale Low voltage input : Up-scale/Down-scale (Selectable) Current input : Value around 0mA High voltage input : Value around 0V Down-scale (RTD input)
Input short action	0.1 to 100.0 sec. (OFF when 0 is set.)
Input digital filter	-span to +span
PV bias	0.500 to 1.500
PV ratio	

Hold function

Peak hold	Highest measured value is held
Bottom hold	Lowest measured value is held
	• The held values can be reset manually, by external contact signal or by communication after the confirmation by the operator.
	• Data is not backed up when the instrument power supply is off.

Display

Display digit	5-digits (The most significant digit : -1 or 1)
Flashing function	Flashing display at input error or event occurrence • Settable flashing function from each event 1 to 6.

Alarm function (Optional)

Number of alarms	Up to 6 points • With 12V DC sensor power supply : Up to 5 points • With 24V DC sensor power supply : Up to 2 points
Alarm type	Process High, Process low • Hold action is available.
Alarm output	Relay contact output, Form a contact 250V AC 3A, 30V DC 1A (Resistive load) • Electric life : 300,000 cycles or more
Differential gap	0 to input span
Other function	a) Energized/de-energized action is configurable. b) Delay timer : 0.0 to 600.0 sec c) Interlock (latch) function is configurable.

Input range Code Table

Temperature • DC Current • DC Low voltage Group

• Use dip switch to change input group.

Thermocouple

Input	Code	Range	Input	Code	Range
K	K : 35	-200.0 to +400.0°C	J	J : A1	0 to 800°F
	K : 40	-200.0 to +800.0°C		J : A2	0 to 1600°F
	K : 09	0.0 to 400.0°C		T : 19	-200.0 to +400.0°C
	K : 10	0.0 to 800.0°C		T : C2	-328.0 to +752.0°F
	K : 41	-200 to +1372°C		S : 06	-50 to +1768°F
	K : 02	0 to 400°C		S : A7	-58 to +3214°F
	K : 04	0 to 800°C		R : 07	-50 to +1768°C
	K : C6	-250.0 to +800.0°F		R : A7	-58 to +3214°F
	K : C4	-328.0 to +400.0°F		E : 21	-200.0 to +700.0°C
	K : A4	0.0 to 800.0°F		E : 06	-200 to +1000°C
	K : C5	-328 to +2502°F		E : A9	-328.0 to +1292.0°F
	K : A1	0 to 800°F		E : B1	-328 to +1832°F
	K : A2	0 to 1600°F		B : 03	0 to 1800°C
	J : 27	-200.0 to +400.0°C		B : B2	0 to 3272°F
J : 32	-200.0 to +800.0°C	N : 02	0 to 1300°C		
J : 08	0.0 to 400.0°C	N : A7	0 to 2372°F		
J : 09	0.0 to 800.0°C	PLII (NBS)	A : 02 0 to 1390°C		
J : 15	-200 to +1200°C	(ASTM)	A : A2 0 to 2534°F		
J : 02	0 to 400°C	W5Re/W26Re	W : 03 0 to 2300°C		
J : 04	0 to 800°C	(ASTM)	W : A2 0 to 4200°F		
J : C7	-200.0 to +700.0°F	U : 04	0.0 to 600.0°C		
J : C6	-328.0 to +1200.0°F	(DIN)	U : B2 32.0 to 1112.0°F		
J : B6	0.0 to 800.0°F	L : 04	0.0 to 900.0°C		
J : B9	-328 to +2192°F	(DIN)	L : A9 32.0 to 1652.0°F		

RTD

Input	Code	Range
Pt100	D : 34	-100.00 to +100.00°C
	D : 35	-200.0 to +850.0°C
	D : 21	-200.0 to +200.0°C
	D : C8	-199.99 to +199.99°F
	D : C9	-328.0 to +1562.0°F
JPt100	P : 29	-100.00 to +100.00°C
	P : 30	-200.0 to +640.0°C
	P : C8	-199.99 to +199.99°F
	P : C9	-328.0 to +1184.0°F
	P : D1	-200.0 to +200.0°F

DC Current • voltage

Input	Code	Range
0 to 10mV	1 : 01	Scale range and decimal point are programmable in the range of -19999 to +19999
0 to 100mV	2 : 01	• The decimal point position (digits below zero) is programmable between 0 and 3.
0 to 1V	3 : 01	
-100 to +100mV	9 : 01	
-10 to +10mV	9 : 03	
0 to 20mA	7 : 01	
4 to 20mA	8 : 01	

*1: In case the communication data digit is 6, the decimal point is ignored and the scale range is -9999 to 19999.

*2: Shunt resistor is not required for current input.

Digital Input (Optional)

Number of inputs	2 points (DI1 and DI2)
Input method	Non-voltage contact input (OPEN : 500kΩ or more, CLOSE : 10Ω or less)
Determination time	50ms
Function	DI1 : Hold reset, DI2 : Alarm interlock reset

Analog Retransmission Output (AO) (Optional)

Output signal	0 to 1V DC, 0 to 5V DC, 1 to 5V DC, 0 to 10V DC Load resistance : More than 1kΩ Output impedance : Less than 0.1Ω
	0 to 10mV DC, 0 to 100mV DC Load resistance : More than 20kΩ Output impedance : Less than 10Ω
	4 to 20mA DC, 0 to 20mA DC Load resistance : Less than 600Ω Output impedance : More than 1MΩ
Output type	Measured value (PV)
Output accuracy	±0.1% of span
Output resolution	More than 12 bits

Communication (Optional)

Communication method	RS-485 (2-wire), RS-422A (4-wire) a) ANSI X3.28 sub-category 2.5A4 (RKC standard) b) MODBUS-RTU • Selectable
Synchronous method	Half-duplex start-stop synchronous type
Communication speed	2400bps, 4800bps, 9600bps, 19200bps, 38400bps
Bit format	Start bit : 1, Data bit : 7 or 8 (For MODBUS 8 bit only) Parity bit : 1 (odd or even) or none, Stop bit : 1 or 2
Maximum connection	32 units (Including host)
Communication data digits	7 or 6 digits

Sensor Power Supply (Optional)

Output voltage	24V DC ±1.2V or 12V DC ±1V
Output current	24V DC type : Less than 24mA DC 12V DC type : Less than 20mA DC
Load resistance	24V DC type : More than 1kΩ 12V DC type : More than 600Ω

General Specifications

Waterproof/Dustproof	NEMA4X, IP66 • Waterproof/Dustproof protection only effective from the front in panel mounted installation.
Supply voltage	a) 90 to 264V AC (50/60Hz, Selectable) Rating : 100 to 240V AC b) 21.6 to 26.4V AC ±10% (50/60Hz, Selectable) Rating : 24V AC c) 21.6 to 26.4V DC Rating : 24V DC
Power consumption	a) At 100V AC : Less than 7.0VA At 240V AC : Less than 10.8VA b) 24V AC : Less than 7.6VA c) 24V DC : Less than 230mA
Memory backup	Backed up by non-volatile memory (FRAM) • Data retaining period : Approx. 10 years • Number of writing : Approx. 1,000,000,000,000,000 times. (Depending on storage and operating conditions.)
Insulation resistance	More than 20MΩ (500V DC) between measured terminals and ground More than 20MΩ (500V DC) between power terminals and ground
Dielectric voltage	1000V AC for one minute between measured terminals and ground 1500V AC for one minute between power terminals and ground
Power failure	A power failure of 20m sec or less will not affect the action. If power failure of more than 20m sec occurs, indicator will restart.
Weight	Approx. 190g
Ambient temperature	-10 to +50°C (14 to 122°F)
Ambient humidity	5 to 95% RH (Non condensing) • Absolute humidity : MAX.W.C 29g/m ³ dry air at 101.3kPa
Compliance with Standards	CE Marking : LVD EN61010-1 OVERVOLTAGE CATEGORYII, POLLUTION DEGREE 2 Class II (Reinforced insulation) EMC EN61326

UL : UL 61010-1

C-UL : CAN/CSA-C22.2 No.61010-1

C-Tick mark : AS/NZS CISPR 11 (equivalent to EN55011)

DC High voltage group

DC voltage

Input	Code	Range
0 to 5V	4 : 01	Scale range and decimal point are programmable in the range of -19999 to +19999
0 to 10V	5 : 01	
1 to 5V	6 : 01	
-1 to +1V	9 : 02	

External Dimensions

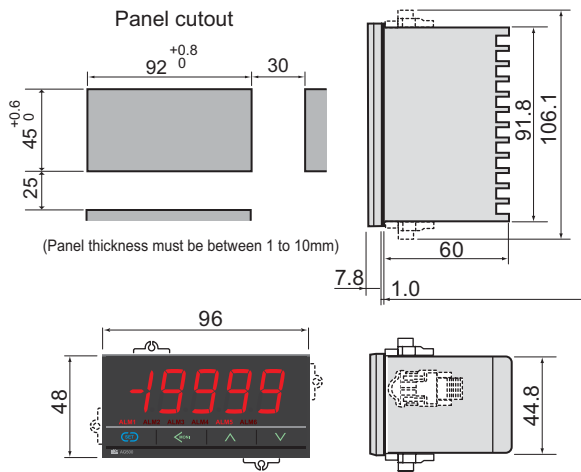

<Close vertical mounting>
* Up to 6 units

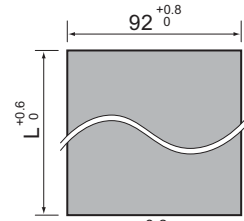

$$L = (48 \times n - 3)^{+0.6}_0$$

n : Number of controllers
(2 ≤ n ≤ 6)

* Waterproof/dustproof is not available for close horizontal mounting.

Rear Terminals

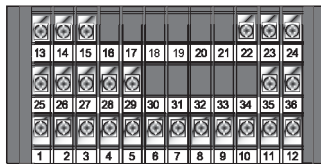

* Use a solderless terminal for screw size M3X6.

Contents	No. 13	14	15	16	17	18	19	20	21	22	23	24				
	COM DI1 DI2			/								(1)		(2)		(3)
Digital input	Measured input		(A) Thermocouple (B) RTD (C) Voltage/Current													
Contents	No. 25	26	27	28	29	30	31	32	33	34	35	36				
	SG T(A) T(B) R(A) R(B)				/								LAO		+	
Communication				Analog retransmission output												
Contents	No. 1	2	3	4	5	6	7	8	9	10	11	12				
	L N 100 to 240V AC 24V AC		COM NO NO		COM NO NO		COM NO NO		COM NO NO		COM NO NO					
Power supply	+		-		24V DC		Sensor power supply		+		-					
	DC24V		Alarm output 6		12V DC		LED drive supply for SP500									
Power supply		Alarm output 1 to 5														

Input Selector Unit (SP500)

The SP500 is an input selector unit with 6 inputs (standard) or 5 inputs (transfer type).
Maximum 3 units can be connected by using transfer type SP500 with 5 inputs.



Specifications

Input type	Thermocouple K,J,E,T,R,S,B,N,L,U RTD Pt100/JPt100 Voltage/Current inputs
Number of inputs	6 points (Transfer switch type : 5 points)
LED display	LED lights by the power supply from the indicator (12V DC)
Life of switch	30 thousand operation (at 70mm/sec.)
Contact resistance	15mΩ (initially), Less than 40mΩ (after 30 thousand operation)
Switching timing	Non-shooting
External dimension	96 x 48 x 100mm
Weight	Approx 250g

Model Code

SP500 - □ □ □

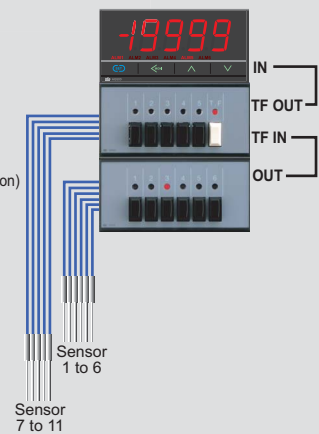
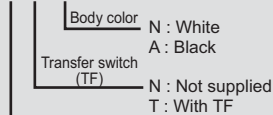

Model and Suffix Code

Specification	Model and Suffix Code	Hardware coding only							Input and Range code
		①	②	③	④	⑤	⑥	⑦	
	AG500 - □ * □ □ □ □ □ □ □ □								
① Power Supply	100 to 240V AC 24V AC/DC	4	3						
② Alarm output	Not supplied Alarm output (Specify 1 to 6)								
③ Contact input (DI)	Not supplied Contact inputs : 2 points			N	2				
④ Sensor power supply/ LED drive supply (For SP500)	Not supplied 12V DC : Sensor power supply or LED drive supply *1 24V DC : Sensor power supply *2			N	P				
⑤ Analog retransmission output (AO)	Not supplied See Analog Output Code Table								
⑥ Communication	Not supplied RS-422A RS-485					N	4	5	
⑦ Quick start code	No quick start code Specify Input and range code Specify Input and range code and quick start code (See page 11)								N 1
⑧ Input and range	See Input range Code Table								2

Analog Output Code Table

1	0 to 10mV DC
2	0 to 100mV DC
3	0 to 1V DC
4	0 to 5V DC
5	0 to 10V DC
6	1 to 5V DC
7	0 to 20mA DC
8	4 to 20mA DC

*1 : When 12V DC (For sensor power supply/LED drive supply) is used, alarm output is max. 5 points.
*2 : When 24V DC (Sensor power supply) is used, alarm output is max. 2 points.

Input range Code Table

Thermocouple

Input	Code	Range	Input	Code	Range	
K	K : 35	-200.0 to +400.0°C	J	J : C7	-200.0 to +700.0°F	
	K : 40	-200.0 to +800.0°C		J : C6	-328.0 to +1200.0°F	
	K : 09	0.0 to 400.0°C		J : B6	0.0 to 800.0°F	
	K : 10	0.0 to 800.0°C		J : B9	-328.0 to +2192°F	
	K : 41	-200.0 to +1372°C		J : A1	0 to 800°F	
	K : 02	0 to 400°C		J : A2	0 to 1600°F	
	K : 04	0 to 800°C	T	T : 19	-200.0 to +400.0°C	
	K : C6	-250.0 to +800.0°F		T : C2	-328.0 to +752.0°F	
	K : C4	-328.0 to +400.0°F		S	S : 06	-50 to +1768°C
	K : A4	0.0 to 800.0°F			S : A7	-58 to +3214°F
	K : C5	-328.0 to +2502°F		R	R : 07	-50 to +1768°C
	K : A1	0 to 800°F			R : A7	-58 to +3214°F
K : A2	0 to 1600°F	E	E : 21	-200.0 to +700.0°C		
J	J : 27		-200.0 to +400.0°C	E : 06	-200 to +1000°C	
	J : 32		-200.0 to +800.0°C	E : A9	-328.0 to +1292.0°F	
	J : 08		0.0 to 400.0°C	E : B1	-328.0 to +1832°F	
	J : 09		0.0 to 800.0°C	B : 03	0 to 1800°C	
	J : 15		-200 to +1200°C	B	B : B2	0 to 3272°F
	J : 02	0 to 400°C	N		N : 02	0 to 1300°C
J : 04	0 to 800°C	N : A7		0 to 2372°F		

RTD

Input	Code	Range
Pt100	D : 34	-100.00 to +100.00°C
	D : 35	-200.0 to +850.0°C
	D : 21	-200.0 to +200.0°C
	D : C8	-199.99 to +199.99°F
	D : C9	-328.0 to +1562.0°F
	JPt100	P : 29
P : 30		-200.0 to +640.0°C
P : C8		-199.99 to +199.99°F
P : C9		-328.0 to +1184.0°F
P : D1		-200.0 to +200.0°F

DC Current - voltage

Input	Code	Range
0 to 10mV	1 : 01	0.0 to 100.0%
0 to 100mV	2 : 01	
0 to 1V	3 : 01	
0 to 5V	4 : 01	
0 to 10V	5 : 01	
1 to 5V	6 : 01	

Input	Code	Range
0 to 20mA	7 : 01	0.0 to 100.0%
4 to 20mA	8 : 01	
-100 to +100mV	9 : 01	
-1 to +1V	9 : 02	
-10 to 10mV	9 : 03	

Quick start code

Quick start code tells the factory to ship with each parameter preset to the values detailed as specified by the customer. Quick start code is not necessarily specified when ordering, unless the preset is requested. These parameters are software selectable items and can be re-programmed in the field via the manual.

Specification	Quick start code	①	②	③	④	⑤	⑥	⑦	⑧
Alarm function 1	No alarm See Alarm Code Table								
Alarm function 2	No alarm See Alarm Code Table								
Alarm function 3	No alarm See Alarm Code Table								
Alarm function 4	No alarm See Alarm Code Table								
Alarm function 5	No alarm See Alarm Code Table								
Alarm function 6	No alarm See Alarm Code Table								

Alarm Code Table

H	Process High	K	Process High with Alarm Hold
J	Process Low	L	Process Low with Alarm Hold

Terminal cover (Sold separately) KFB400-58



Conventional indicator : REX-AD410



<Comparison of function>

	REX-AD410	AG500
Display digits	4	5
Sampling time	0.5 sec	0.25 sec
Analog output resolution	10 bits	More than 12 bits
Sensor power supply	Not available	Available
Alarm output	Max. 6 points 2 points/1 common x 3	Max. 6 points 2 points/1 common x 2 1 point independent output x 2
Depth	100mm	60mm
RoHS	Not available	Available



- Before operating this product, read the instruction manual carefully to avoid incorrect operation.
- This product is intended for use with industrial machines, test and measuring equipment. It is not designed for use with medical equipment.
- If it is possible that an accident may occur as a result of the failure of the product or some other abnormality, an appropriate independent protection device must be installed.

Caution for the export trade

All transactions must comply with laws, regulations, and treaties.

Caution for imitated products

As products imitating our product now appear on the market, be careful that you don't purchase these imitated products. We will not warrant such products nor bear the responsibility for any damage and/or accident caused by their use.



SOUTHEAST THERMAL SYSTEMS

WWW.SETHERMAL.COM

RFQ@SETHERMAL.COM

PHONE: 704-399-4248