



Q4/Q4-X

Universal HART-compatible 2-wire Transmitters



Q4/Q4-X are smart and universal 2-wire in-head transmitters for temperature and other measurement applications. Q4/Q4-X are fully HART-compatible, with communication through the HART protocol.

- Utilizes HART Protocol for remote configuration and monitoring
- Communicates with HART Communicator or PC via modem
- Fully universal, linearized and isolated
- Accepts RTD, T/C, mV and Ω
- Sensor error correction
- Easy wiring, large center hole
- 50 point linearization – any sensor can be matched
- Consistent sensor break function
- Full access to all features while in operation
- Low sensor isolation detection
- Integrated in Emerson AMS and Siemens PDM systems

Specifications:

Input RTD and Resistance	3-,4-wire connection
Pt100 ¹⁾ and D100 ²⁾	-200 to +1000 °C / -328 to +1832 °F
Pt1000 ¹⁾	-200 to +200 °C / -328 to +392 °F
PtX 10 ≤ X ≤ 1000 ¹⁾	Upper range depending on X value
Ni100 ³⁾	-60 to +250 °C / -76 to +482 °F
Ni1000 ³⁾	-60 to +150 °C / -76 to +302 °F
Potentiometer / resistance	0 to 2000 Ω
Input Thermocouples	B, C, E, J, K, L, N, R, S, T, U
Input Voltage	-10 to +500 mV
Sensor failure / Low isolation	User definable output
Adjustments - Zero	Any value within range limits
Adjustments - Minimum spans	
Pt100, Pt1000, Ni100, Ni1000	10 °C / 18 °F
Potentiometer	10 Ω
T/C, mV	2 mV
Output	4-20 / 20-4 mA
Operating temperature	-40 to +85 °C / -40 to +185 °F
Galvanic isolation	1500 VAC, 1 min
Power supply	Q4 10 to 42 VDC
	Q4-X 12 to 30 VDC
Intrinsic safety	
Q4-X ATEX:	II 1 G EEx ia IIC T4-T6
Q4-X FM:	IS Class I-III, DIV 1, GP A-D, G
Q4-X CSA:	Class I, Groups A-D; Class II, Group G; Class III
Typical accuracy	±0.1% of temperature span
Connection head	DIN B or larger

¹⁾IEC 60751, $\alpha=0.00385$ ²⁾Pt100 acc. to JIS 1604, $\alpha=0.003916$ ³⁾DIN 43760

Input connections

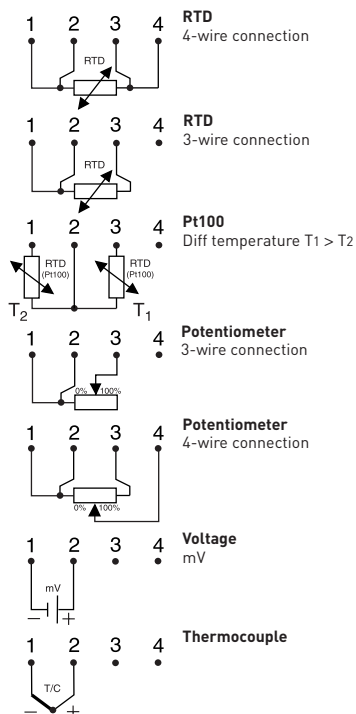

Output connections

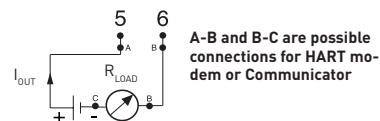

Output load diagram

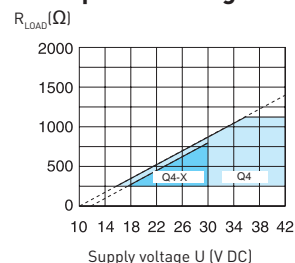

$$R_{LOAD} = (U-10)/0.023 \text{ (Q4)}$$

$$R_{LOAD} = (U-12)/0.023 \text{ (Q4-X)}$$

Dimensions

