



## Proportional Valve

SPV-38U-C



Refer carefully to this manual before operation.

# SPV-U Series

## ■ Coding Principle

SPV - xxU - C

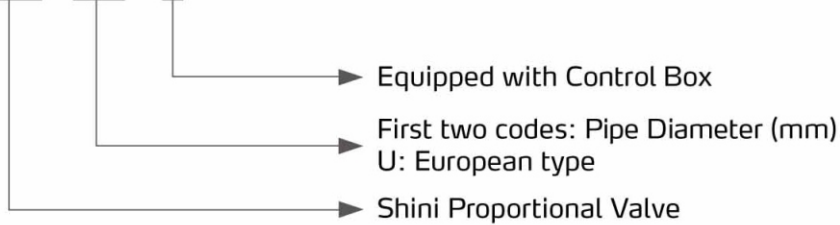

## ■ Features

### Standard configuration

- European type design, classy appearance, easy installation and operation.
- Unique design of valve body, make material conveying more smooth.
- The performance of solenoid valve is so stable that the air cylinder acts accurately to ensure a proportional mixing of new and regrind materials.
- There is no need of ordering control box when working with SAL-U series hopper loaders.
- Instant recycling of regrind materials to reduce production cost.
- Control box is optionally available when performing in other situations. Equipped with 1~4 levels working function selection, making material mixing more evenly.

### Accessory option

- When applied in other conditions, control cabinet can be an option.

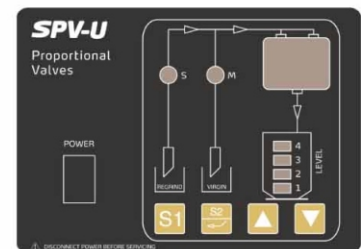

Control Panel

## ■ Application

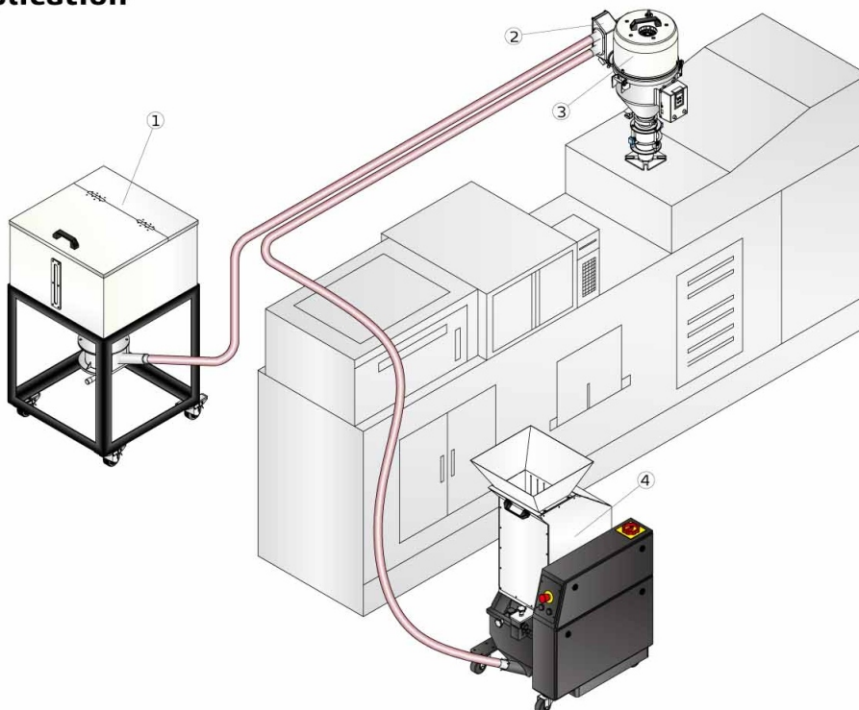

1. Material storage tank
2. Proportional valve
3. "Standard" self-contained hopper loaders
4. Low-speed granulator

## Working Principle

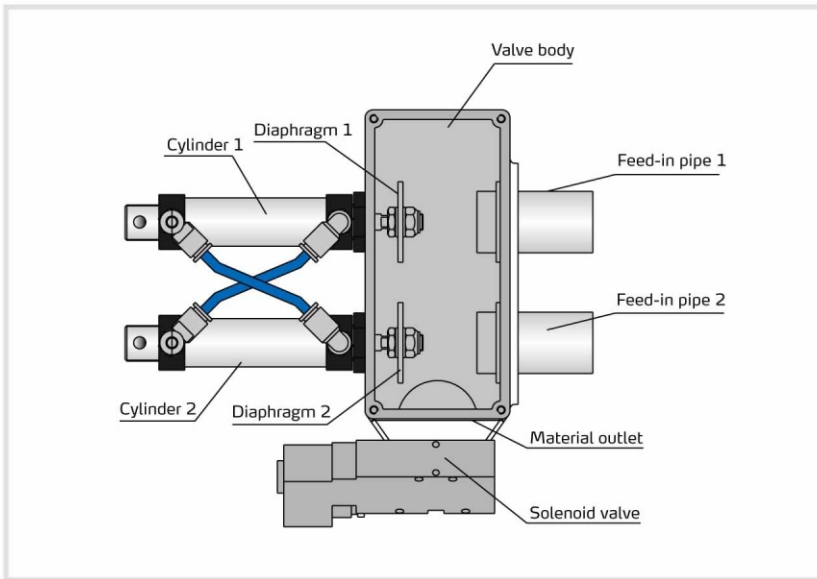

After material loading time and the proportion of secondary material have been set, the cylinder tank will control the feeding proportion of new materials and secondary materials in hopper by driving opening & closing and start time of diaphragm 1 and 2 so as to accomplish the proportioned mixing.

## Outline Drawings

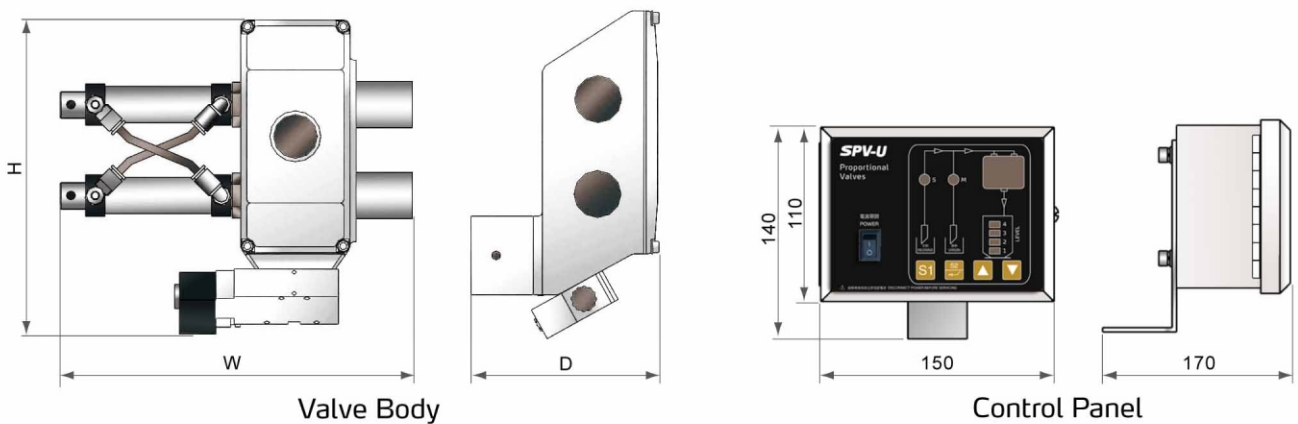

## Specifications

Model	Compressed Air Pressure	Driven Means	Maximum Material Flow	Pipe Size (inch)	Dimensions (mm) H × W × D	Weight (kg)
SPV-38U-(C)	3kgf/cm <sup>2</sup>	Cylinder	350kg/hr	1.5	270 × 300 × 150	3.5
SPV-50U-(C)	3kgf/cm <sup>2</sup>	Cylinder	550kg/hr	2	270 × 300 × 150	3.8

Notes: 1) "C" stands for control cabinet, there is no need of control box when working with SAL-U loaders.

2) Above maximum passing rate is based on pellet material of 0.65kg/L in bulk density and 3-5mm in diameter.

3) Power supply: 1Φ, 115 / 230VAC, 50 / 60Hz.

We reserve the right to change specifications without prior notice.

## Shini Group

Addr: No. 23, Minhe St., Shulin Dist.,  
New Taipei, Taiwan

Tel: +886 2 2680 9119

Fax: +886 2 2680 9229

Email: [shini@shini.com](mailto:shini@shini.com)

### Factories:

- Taiwan
- Dongguan
- Pinghu
- Ningbo
- Mumbai

2013-09-15-04 Copyrights Reserved.

[www.shini.com](http://www.shini.com)