

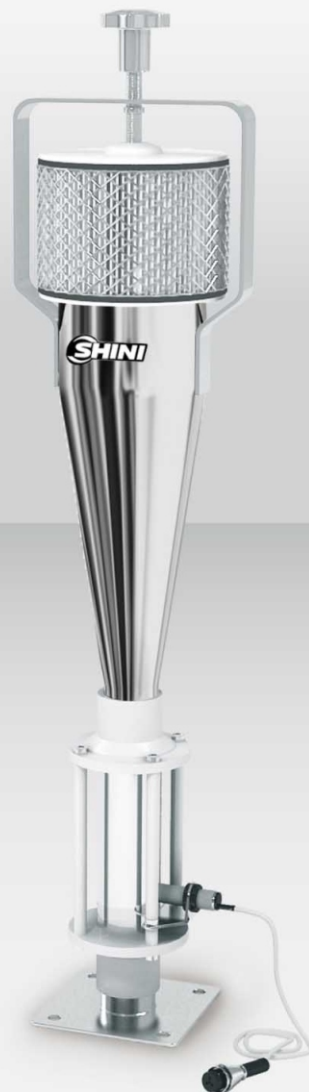

Venturi Loader

VL-100



Refer carefully to this manual before operation.

VL Series

■ Coding Principle

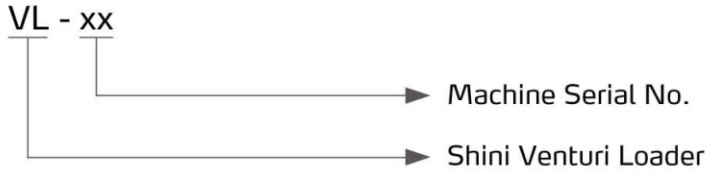

■ Features

- European Type appearance , compact in size and light-weighted.
- Filtered air exhaust does not pollute environment.
- Silent operation, it uses high-pressure air to convey materials.
- Capacitive sensor mounted on the glass-tube for accurate level monitoring.
- Compressed air filter and regulator to eliminate moisture and maintain stable air pressure.
- Quick installation and easy operation with surface polished,add "P" at the end of model code.
- Easy access to material hopper for convenient cleaning.



VL-50



Filter and Control Units

■ Application

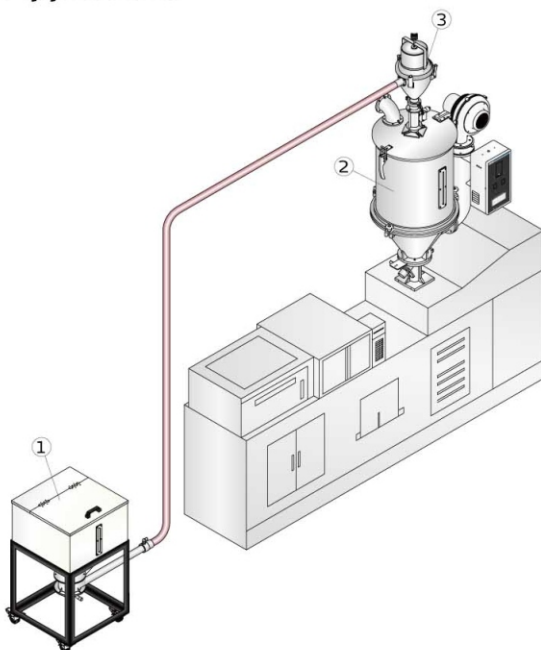

1. Material tank
2. Hopper dryer
3. Venturi loaders
4. Single-color doser

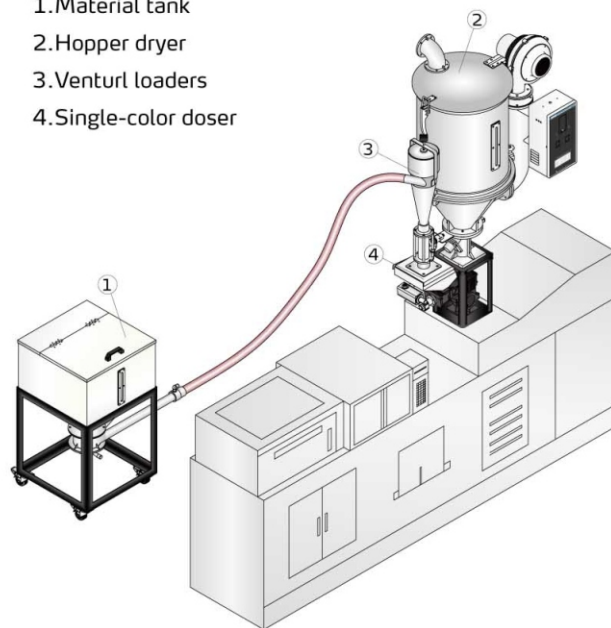

Structure

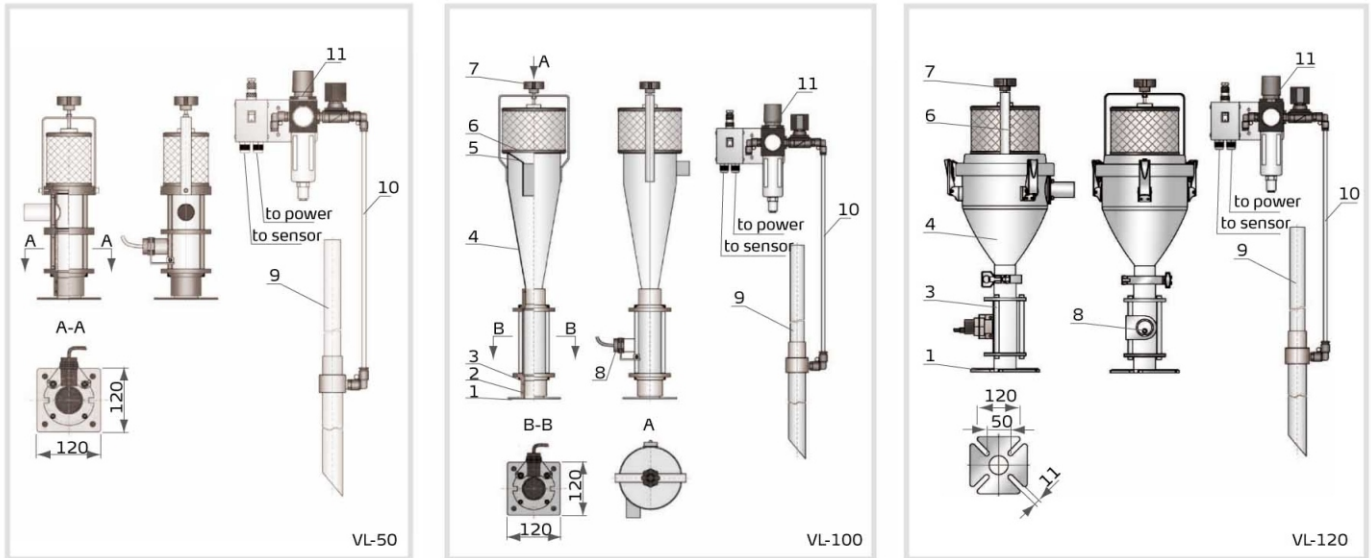

1. Base 2. O-ring 3. Flange connecting pole 4. Hopper 5. Material flap
 6. Filter 7. Fixing knob 8. Sensor 9. Conveying pipe 10. Air pipe
 11. Compressed-air filter, lubricator cap & regulator

Specifications

Model		VL-50	VL-100	VL-120
Conveying Capacity	kg/hr	40	60	80
	lb/hr	88	132	176
Material Hopper	L	0.5	2.8	3
	gal	0.13	0.74	0.79
Air Flow	L/hr	6,000	6,000	6,000
	gal/hr	1,585	1,585	1,585
Compressed Air (kgf/cm ²)		6.0	6.0	6.0
Max. conveying distance	m	6	6	6
	inch	236	236	236
Conveying Pipe (inch)		1.25	1.25	1.25
Length of Suction Pipe	mm	900	900	900
	inch	35	35	35
Dimension (H×W×D)	mm	380×145×150	720×165×160	630×240×280
	inch	15×5.7×5.9	28.3×6.5×6.3	24.8×9.4×11
Weight	kg	4.5	7	7.5
	lb	9.9	15.4	16.5

Notes: 1) Test condition of conveying capacity: Plastic material of bulk density 0.8kg/L(6.7lb/gal), dia. 3~5 mm/0.12~0.2inch, vertical conveying height: 2m/79inch, horizontal conveying distance: 1m/39inch.

2) Power supply 1Φ, 115/230V, 50/60Hz.

We reserve the right to change specifications without prior notice.

Shini Group

Addr: No. 23, Minhe St., Shulin Dist.,
New Taipei, Taiwan

Tel: +886 2 2680 9119

Fax: +886 2 2680 9229

Email: shini@shini.com

Factories:

- Taiwan
- Dongguan
- Pinghu
- Ningbo
- Chongqing
- Pune

2017-02-15-04 Copyrights Reserved.

www.shini.com