

Jet Air Heater & Control Panel

FOR SAFETY & LONG HEATER LIFE, CAREFULLY READ THIS MANUAL BEFORE USE.



Safety



SHOCK HAZARD!

Only qualified individuals should install this heater and related controls. Follow all applicable electrical codes and use proper wiring.



BURN/FIRE/EXPLOSION HAZARD!

Do not use in hazardous environments, and/or near explosive or reactive gases, or combustible materials. Avoid contact with the heater or exit accessories during or soon after operation. **DO NOT USE NEAR VOLATILE OR COMBUSTIBLE MATERIALS.**

Description

The Jet provides a compact, efficient heater for heating air or inert gases to 1400°F (760°C) in either a 3kW or 8kW, 240V 1PH unit. Two (2) type “K” thermocouples with a convenient terminal block are included for ease of wiring. One thermocouple measures inlet air temperature (S1) and the other can be used for exit/process air temperature (S2). When powered and controlled with the Jet Control Panel (sold separately) you are provided a convenient, cost effective solution for safely controlling the AC power to your Jet. If operated correctly, the heater will operate continuously for 5000 hours or longer.

Limited Warranty

TUTCO SureHeat warrants that all products to be delivered hereunder will be free from defects in material and workmanship at the time of delivery. TUTCO SureHeat's obligation under this warranty shall be limited to (at its option) repairing, replacing, or granting a credit at the prices invoiced at the time of shipment for any of said products. This warranty shall not apply to any such products which shall have been repaired or altered, except by TUTCO SureHeat, or which shall have been subjected. TUTCO SureHeat shall be liable under this warranty only if (A) TUTCO SureHeat receives notice of the alleged defect within sixty (60) days after the date of shipment; (B) the adjustment procedure hereinafter provided is followed, and (C) such products are, to TUTCO SureHeat's satisfaction, determined to be defective.

THE WARRANTY SET FORTH IN THE PRECEDING PARAGRAPH IS EXCLUSIVE AND IN LIEU OF ALL OTHER WARRANTIES, EXPRESS OR IMPLIED, INCLUDING, WITHOUT LIMITATION, ANY IMPLIED WARRANTY OF FITNESS FOR A PARTICULAR PURPOSE OR OF MERCHANTABILITY.

The information contained in this manual is based on data considered to be true and accurate. Reasonable precautions for accuracy has been taken in the preparation of this manual, however TUTCO SureHeat assumes no responsibility for any omissions or errors, nor assumes any liability for damages that may result from the use of the product in accordance with the information contained in this manual.

Please direct all warranty/repair requests or inquiries to the place of purchase, and provide the following information, in writing:

- (A) Order number under which products were shipped
- (B) Model/Serial Number of product
- (C) Reason for rejection

PRODUCTS CAN NOT BE RETURNED TO TUTCO SUREHEAT WITHOUT AUTHORIZATION.

Replacement, repair, or credit for products found to be defective will be made by the place of purchase. All products found to be not defective will be returned to the Buyer; transportation charges collect or stored at Buyers expense.

Heater Models and Parts List

Part Number	Maximum Wattage	Maximum Volts	Maximum Amperage	Maximum Temperature
F074718	3000	240 – 1Ø	12.5	1400°F / 760°C
F074719	8000	240 – 1Ø	33.3	1400°F / 760°C

Specifications

Maximum Inlet Air Pressure 60 PSI (4 BAR)
Maximum Inlet Air Temperature 200°F (93°C)
Maximum Exit Air Temperature 1400°F (760°C) *(see page 10 for Performance Curves)*
Minimum Airflow 120 SCFH (57 SLPM)

Exit Air Connection: 1" FNPT
Inlet Air Connection: 3/4" FNPT
Safety Approvals: Heater: CE, UL Recognized, CSA
Control Panel: CE, UL Listed, CSA

Control/limit sensors: Type "K" isolated, ungrounded, exposed junction TCs:
S1 measures Inlet temperature
S2 measures Exit temperature

General Information

Environmental Conditions:
Ambient Temperature 32°F to 104°F (0°C to 40°C)
Humidity 0% to 95% R.H.

Ventilation:
Use in a well-ventilated area away from excess dust, dirt, and moisture.

Cleaning:
With unit OFF and unplugged, exterior surfaces may be wiped clean using a dry, lint-free cloth.

Protective Earthing:
Each heater comes with a convenient grounding stud and hardware located at the inlet of the heater for protective means of earthing.

Dimensions/Mounting

NOTE: The inlet side of the heater is located where the leads/power feedthrus come out of the housing. Failure to install the heater in its proper orientation can result in heater damage and is not covered under the manufacturer's warranty.

Heater Dimensions:

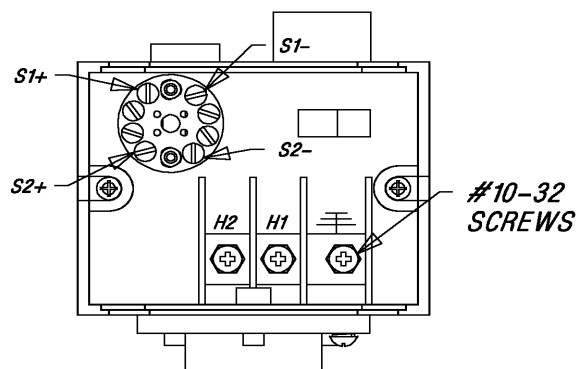
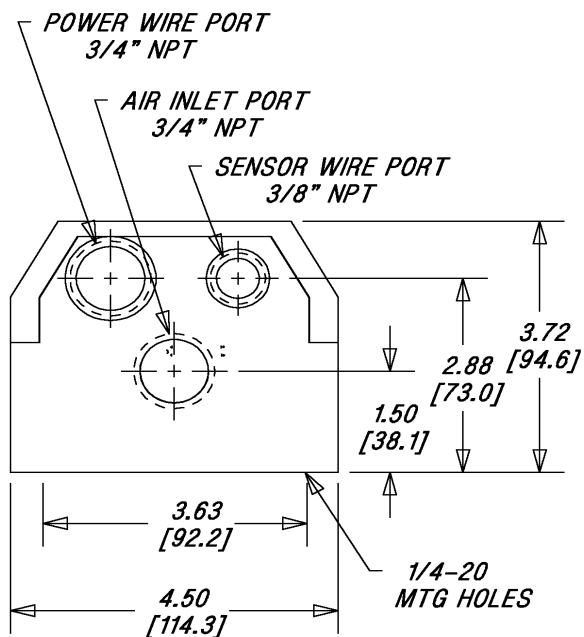
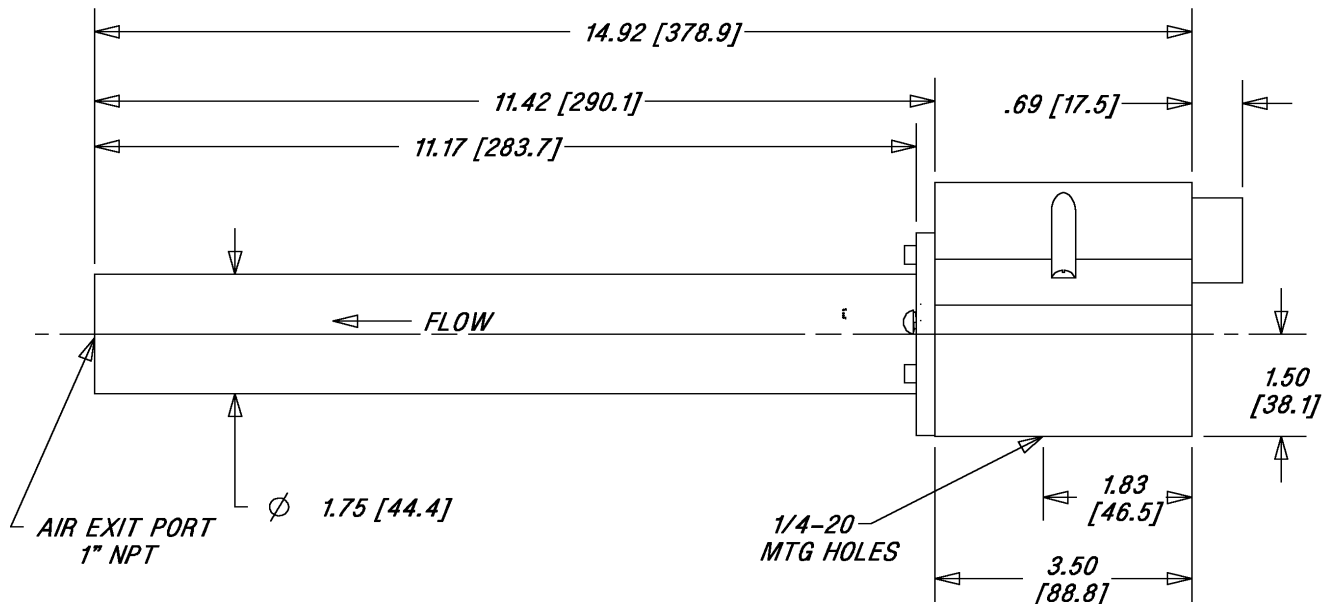

WARNING: Avoid Damage to Housing

3/8" NPT (Sensor): 4 ft-lb
3/4" NPT (Power): 25 ft-lb
3/4" NPT (Air): 25 ft-lb
(Excessive force will crack housing and void warranty)

JET Control Panel Dimensions:

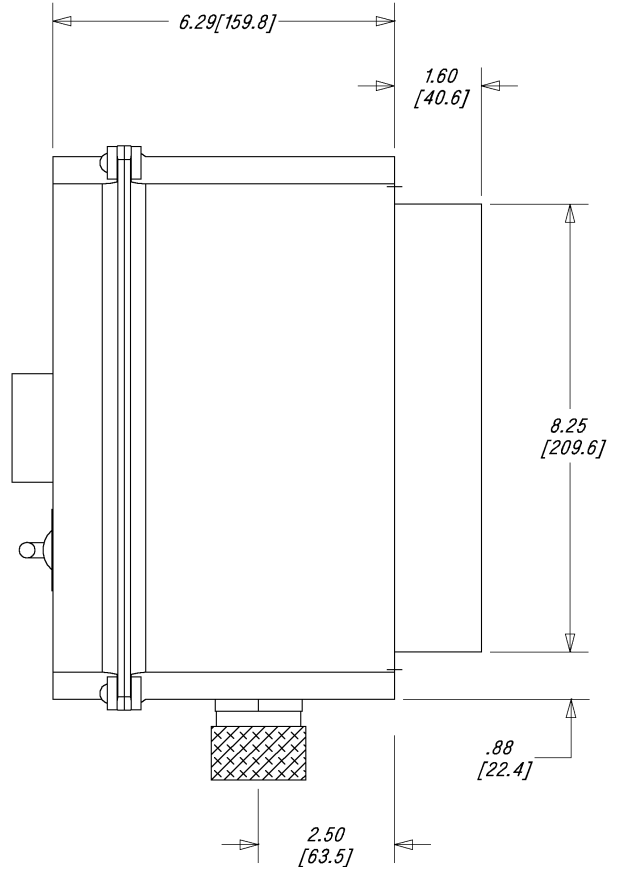
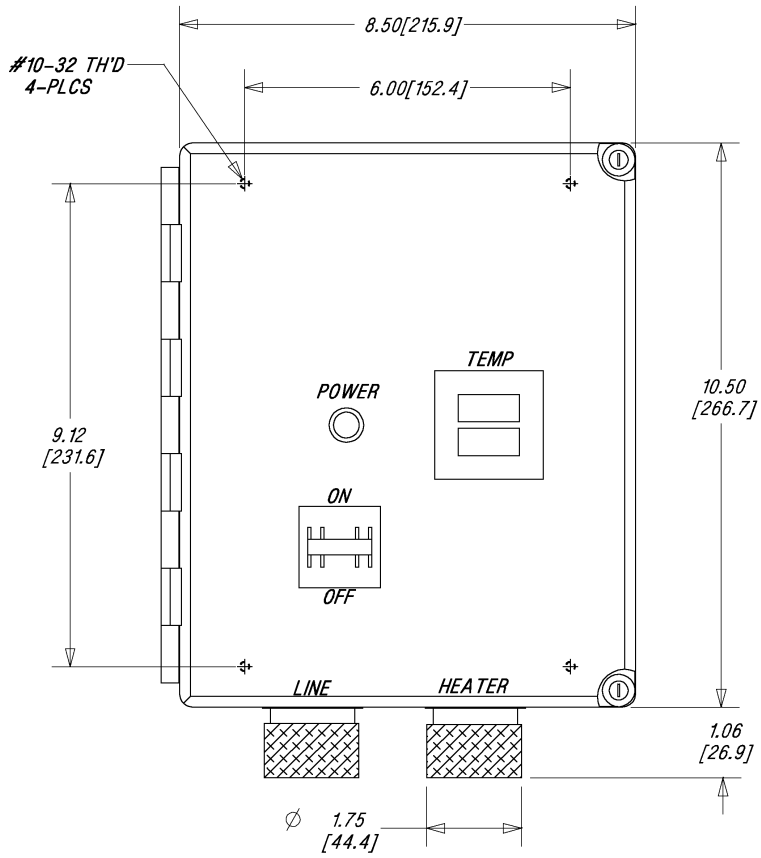

Precautions

1. Use filtered air. Avoid grease, oil, or oil vapors, corrosive or reactive gases which will damage heater.
Note: When using compressed air a pressure reduction valve and an oil & water separation unit should be installed to avoid contaminating the heater and reduce heater life.
2. Operate at safe voltages as shown on the Performance Curves (*see page 10*). Excess voltage will cause premature failure.
3. Using the Jet heater with the Jet Control Panel provides loss of airflow protection if wired properly.
4. If using other form of controls you must always have sufficient airflow through the heater before applying power. Otherwise element will overheat very quickly, and burn out. It is highly recommended that the S1 thermocouple supplied with the heater be used with a temperature limiting board to protect against low/no airflow (TUTCO SureHeat Part #074835 – set to 300°F (150°C)).
5. If using a process air temperature thermocouple other than the supplied S2 thermocouple it is highly recommended that the S2 thermocouple be used with a temperature limiting board to protect against over temperature protection (TUTCO SureHeat Part #074835 – set to 1405°F (763°C)).
6. If using closed-loop control, use a temperature controller with a fast sampling period (<500ms) and minimal overshoot.

Installation

Securely mount the heater before wiring.

- **WARNING:** THE INLET AIR/GAS SIDE OF THE HEATER IS THE PLASTIC HOUSING END WHERE THE POWER TERMINALS AND THERMOCOUPLE TERMINAL BLOCK IS LOCATED. INSTALLING THE HEATER IN THE WRONG ORIENTATION WILL DAMAGE THE HEATER AND CAN CREATE ADDITIONAL HAZARDS AS A RESULT.

1. Wire heater according to diagram on page 8. Follow applicable electrical codes when mounting and wiring system.
2. Note that customer is responsible to supply wiring for A) HEATER TO CONTROL, and B) CONTROL TO MAIN POWER:

A) HEATER TO CONTROL (G, H1, H2) and (S1, S2)

- a. "K" THERMOCOUPLE WIRES must be Teflon Coated and Teflon Insulated, note RED is NEGATIVE (-).
 - i. S1 Type "K" Thermocouple Sensor on heater connects to INLET LIMIT controller. TUTCO SureHeat sets INLET TEMP LIMIT to 300°F (150°C).
 - ii. S2 Type "K" Thermocouple Sensor on heater connects to EXIT TEMP controller. TUTCO SureHeat sets EXIT TEMP ALARM to 1405°F (763°C).
- b. HEATER TO CONTROL (G, H1, H2) POWER WIRES are standard 10 to 14 Gauge, 3 wire (H1, H2, Ground) electrical cable.

B) CONTROL TO MAIN POWER (L1, L2, GND)

- c. MAIN POWER WIRES are standard 10 to 14 Gauge, 3-wire (H1, H2, Ground) electrical cable.
- d. MAIN POWER WIRE fuses must be sized based on maximum heater current. (3kW – 15A, 8kW – 35A)



Proper Torque Values for Fittings

WARNING: Avoid Damage to Housing

3/8" NPT (Sensor): 4 ft-lb

3/4" NPT (Power): 25 ft-lb

3/4" NPT (Air): 25 ft-lb

(Excessive force will crack housing and void warranty)

Typical Wiring:

Jet Control Panel for Closed Loop Control

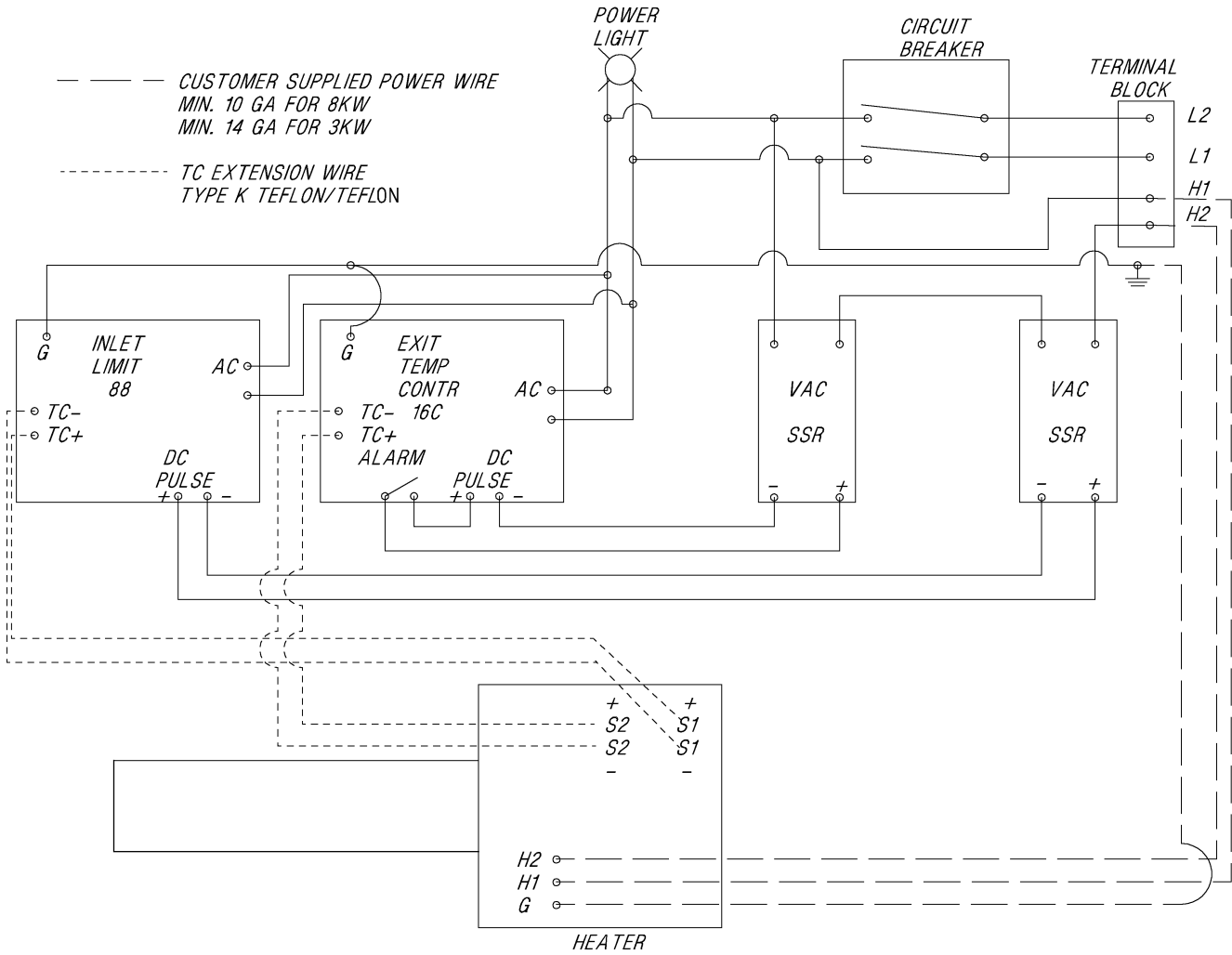

Operation (with Heater)

START-UP

1. Reference the Performance Curves section (*see page 10*) for operational parameters before attempting to operate heater(s).
2. Connect air source to heater.
3. Turn on air and set pressure or flow to desired operating level.
4. Energize MAIN POWER line, and turn on Jet Control circuit breaker.
5. During operation, with constant airflow, the exit temperature will vary only a few degrees from set point. Although the heater will not burn out with zero airflow, if the heater is operated in a vertical downward position and an airflow of 2 SCFM or less is run through the heater, the inlet temperature of the heater will exceed 300°F (150°C) and the low limit controller will begin to limit power to the heater.
6. If using a closed loop system (Jet Control Panel), turn on power to the temperature and power controller, then set the desired temperature on the temperature controller. If using an open loop system, increase power to the heater through the power controller until the desired temperature is attained.

SHUT-DOWN

1. Turn off Jet Control circuit breaker, or disconnect MAIN POWER line.
2. Allow air to continue to flow for a minimum of 1 minute or until exit air temperature is 300°F (150°C) or less for safety. Continue airflow longer as necessary to prevent burn hazard to personnel.
3. Turn off air to the system.

Performance Curves

The attached performance curves show exit air temperatures at different airflows and voltages. Pressure readings (longer dashed lines) are measured at the inlet to the heater with no entrance or exit restrictions. Solid lines indicate safe, normal-life operating conditions. The shorter dash lines indicate marginal, shorter-life operating conditions leading to premature burnout. With a known flow (or pressure) at the heater entrance, follow the flow (or pressure) line across until it meets the desired temperature curve. Drop a line straight down to intersect the x-axis. This point, along the “Heater volts – true RMS” axis, represents the voltage required to generate the desired exit air temperature at the chosen flow rate (inlet pressure).

Jet Maximum Performance

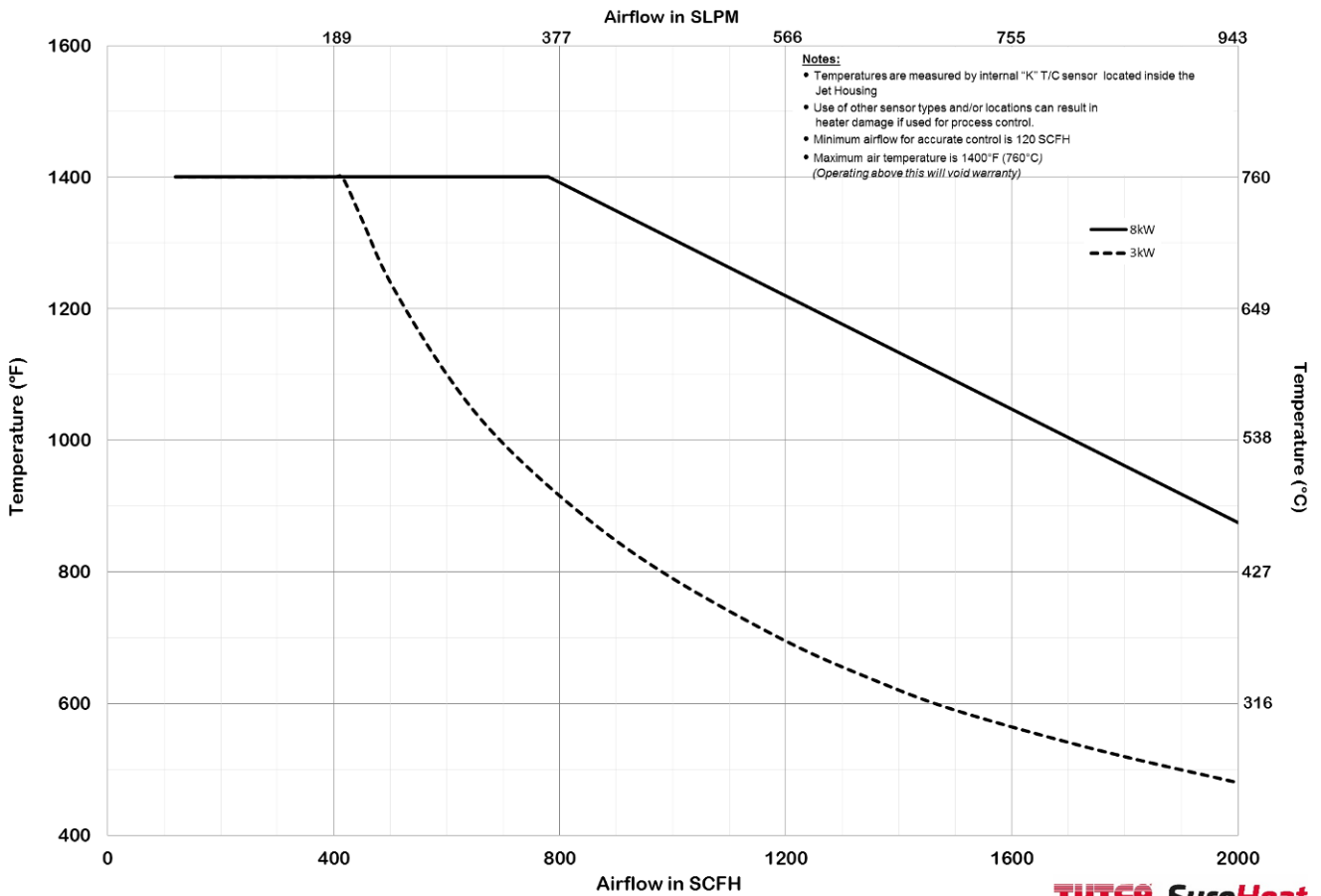

Rev: 05/12

Jet Performance Curve - 3kW

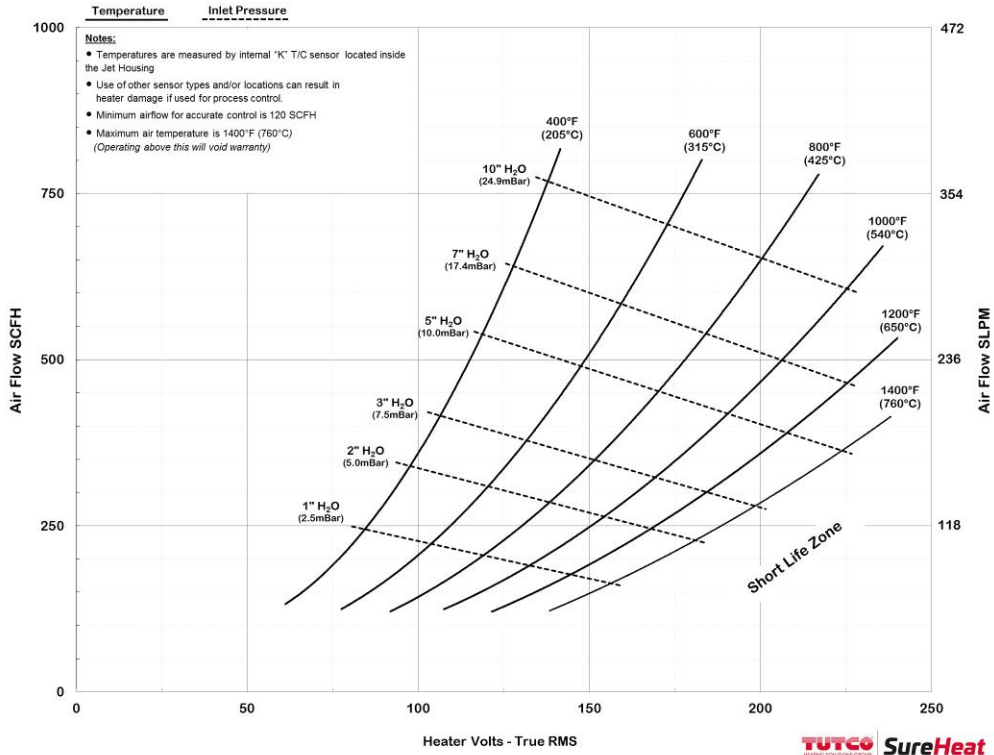

Jet Performance Curve - 8kW

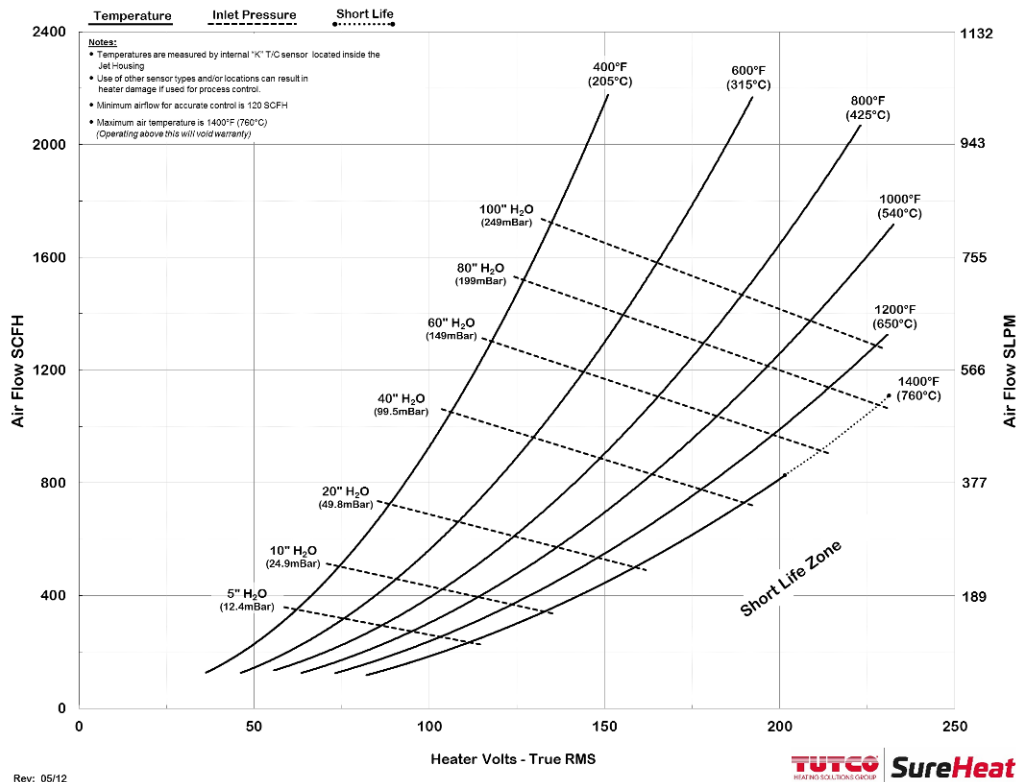

Troubleshooting and Replacing Heaters

1. Note that “TYPICAL” Element Life is APPROXIMATELY 5000 hours. This is based on heater element operating at or below temperatures shown on PERFORMANCE CURVE(S). In addition to normal end of life, elements can fail due to mechanical damage, or problems with the control system.
2. If an element has failed prematurely, it should be inspected to determine the cause of the element failure.
3. When replacing or troubleshooting heaters, turn off power to the system and be sure to follow lock-out/tag-out procedures.
 - a. For Troubleshooting Heater
 - i.) Use multi-meter to check continuity between:
 1. Power terminals H1-H2
 2. Thermocouples positive (+ yellow) to negative (- red)
 - ii.) If there is continuity on all above tests, check system wiring:
 1. Crossed thermocouple wires.
 2. Reversed thermocouple wire polarity – Note: RED is NEGATIVE (-).
 3. Verify inlet air temperature is below set point on INLET TEMPERATURE controller.
 - iii.) If there is no continuity on any test, then contact your local TUTCO SureHeat representative for assistance.
4. Remove entire heater assembly from system. Internal components are typically not replaceable.
5. Reconnect thermocouples, power and ground wires for new/replacement heater.
6. Attach any covers and operate heater per operating manual.

Element Life Curve

(This is published by the element wire manufacturer. It is considered typically and not a guaranteed life)

The life of a TUTCO SureHeat heater is directly based on the temperature of the filament wire. The curve below shows that 5000 hours of life can be obtained by maintaining a filament temperature below 1900°F (1038°C). Also note that the element does not fail until it reaches more than 2200°F (1204°C)!

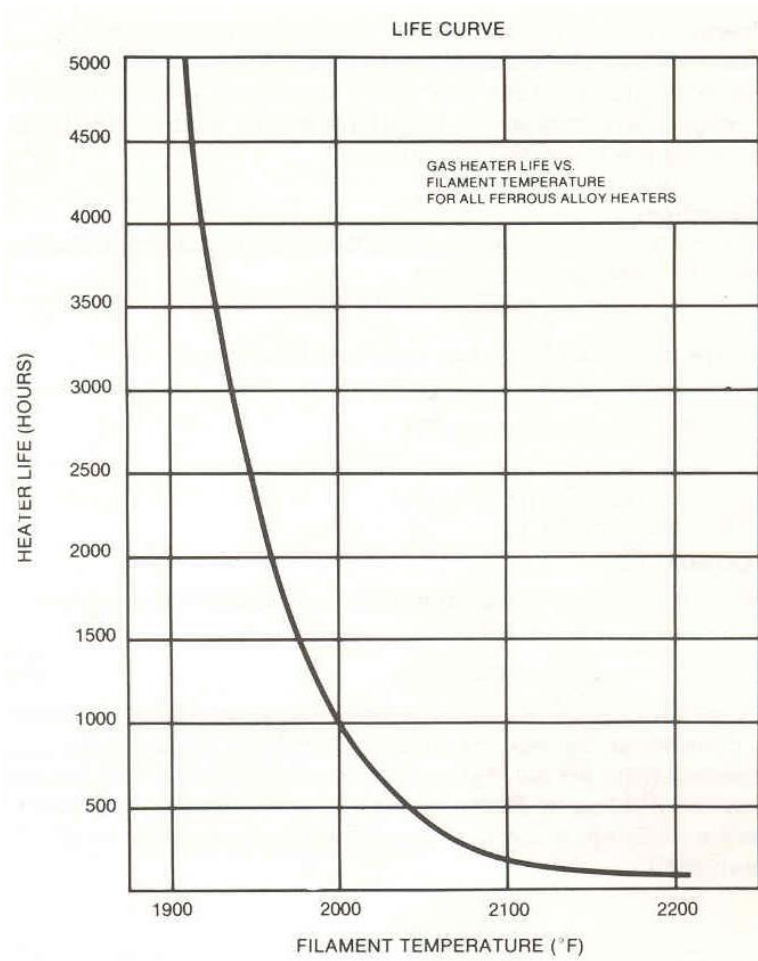

The technical data and specifications supplied in this operating manual are subject to change without prior notice. Contact TUTCO SureHeat for additional assistance.