

FLOW TORCH™

FT 600



Shown with optional inlet & exhaust fittings

- The Flow Torch™ 600 is a 6" diameter stainless steel air heater designed for high flow rates at low pressure drop due to its efficient design with minimal flow restrictions.
- The Flow Torch™ 600 is capable of operating with airflow of 1100 SCFM and up to 3 PSIG.
- UL component recognized (UL File # E365755)

Wattage & Voltage Options

208V, three phase, 5.0kW-33.0kW
 240V, three phase, 5.0kW-35.0kW
 380V, three phase, 10.0kW-45.0kW
 480V, three phase, 10.0kW-60.0kW
 575V, three phase, 10.0kW-60.0kW

Fitting Options

Inlet Fitting:
 3T- 3" O.D. Tube
 4T- 4" O.D. Tube
 5T- 5" O.D. Tube
 NF- No Fitting (6" O.D.)
Exhaust Fitting:
 3T- 3" O.D. Tube
 4T- 4" O.D. Tube
 5T- 5" O.D. Tube
 NF- No Fitting (6" O.D.)

Other Options

Thermocouple Fitting
 Thermocouple
 Insulation Blanket

Specifications

Category: Open Coil Heaters,
 Inline Heaters, Process Heaters
 Max. wattage: 60kW
 Max. exhaust air temp.: 900°F
 Max. inlet air temp.: 250°F
 (consult factory for higher inlet temp.)
 Max. SCFM: 1100
 Max allowable pressure: 3 psig
 Mounting: Horizontal/Vertical
 Heater Body: Stainless Steel 304
 Inlet Fitting: Stainless Steel 304
 Exhaust Fitting: Stainless Steel 304

Wattage	Min. SCFM Req.
10kW	38.2
15kW	57.2
20kW	76.3
25kW	95.4
30kW	114.5
35kW	133.6
40kW	152.6
45kW	171.7
50kW	190.8
55kW	209.9
60kW	229.0

Airflow (SCFM)	Pressure Drop (H2O) w/o fittings	Pressure Drop (H2O) 4" fittings
230	0.2	1.6
330	0.4	3.3
430	0.7	5.5
530	1.1	8.4
630	1.6	11.9
730	2.1	16.0
830	2.8	20.7
930	3.5	25.9
1030	4.2	31.8
1100	4.8	36.3

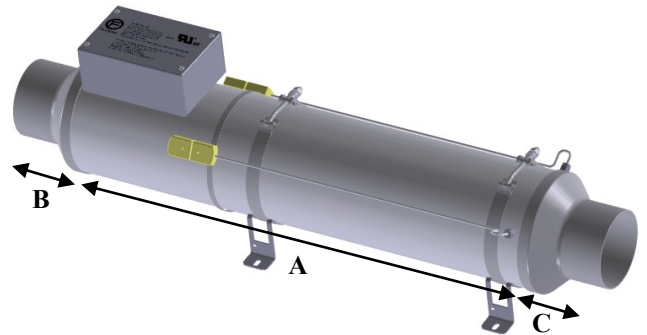

Visit www.farnam-custom.com for detailed drawings

A	Inlet Fitting	B	Exhaust Fitting	C
26.5"	NF	0	NF	0
26.5"	4T, 5T	3.5"	4T, 5T	3.5"
26.5"	3T	3.75"	3T	3.75"

Part Number Key

FT600	10000	240	3	4T	4T	TF2	(XXX)
Flow Torch 600	Wattage	Voltage	Phase	Inlet Fitting	Exhaust Fitting	Thermocouple Fitting	Modification

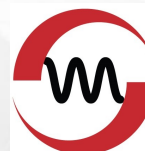

SOUTHEAST THERMAL SYSTEMS
 WWW.SETHERMAL.COM SALES@SETHERMAL.COM phone: 704-399-4248