

# HEAT TORCH™



# HT 030

- The Heat Torch™ 030 inline heater is ideal for concentrating hot air streams into small areas with negligible heat losses.
- This 0.313" (7.95mm) diameter air heater is our smallest standard Heat Torch™ delivering greater precision with focused air stream. It can be mounted vertically or horizontally. (Horizontal mounting is preferred at high temperatures.)
- Heat Torch™ 030 operates best with air flow in the range of 0.3 SCFM to 1 SCFM and power options up to 300 watts [in either 120V or 240V supply]. Maximum recommended exhaust temperature is 932°F (500°C).
- Applications for the Heat Torch™ 030 include melting, cutting, adhesive activation, de-soldering, heat staking, and sterilization.

## Specifications

<b>Category:</b>	Inline Heaters, Process Heaters, Open Coil Heaters.
Max. wattage:	0.3kW
Max. exhaust air temp.:	932°F
Max. inlet air temp.:	250°F
Min. SCFM:	0.3
Max. SCFM:	1.0
Max Allowable Pressure:	120 psig
Mounting:	Horizontal/Vertical
Leads:	20 gauge (12" long)
Heater Body:	Stainless Steel
Inlet Fitting:	Stainless Steel
Exhaust Fitting:	Stainless Steel

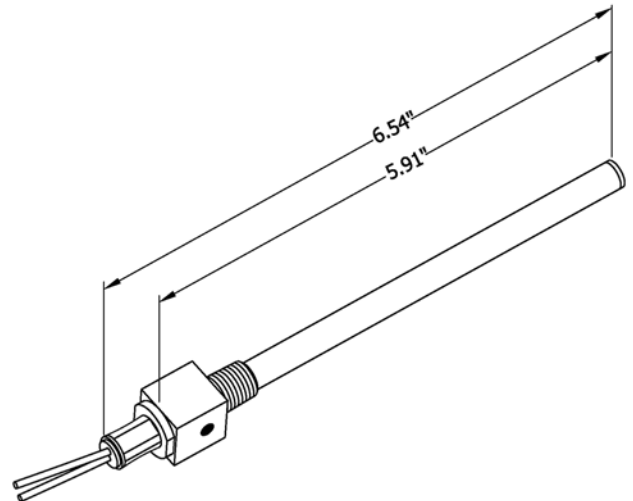

### Wattage & Voltage Options

120V, single phase 50W-250W  
208V, single phase, 100W-250W  
240V, single phase. 100W-300W

### Fitting Options

**Inlet Fitting:**  
10/32- 10-32 UNF thread  
M6 thread

**Exhaust Fitting:**  
NF- No Fitting

Part Number Key					
HT030	50	120	10/32F	NF	(XXX)
Heat Torch 030	Wattage	Voltage	Inlet Fitting	Exhaust Fitting	Modification



# SOUTHEAST THERMAL SYSTEMS

WWW.SETHERMAL.COM

SALES@SEETHERMAL.COM

phone: 704-399-4248