

# HEAT TORCH™



Shown with optional inlet & exhaust fittings

# HT075

- Our Heat Torch™ 075 is a 0.75" diameter compact inline air heater providing moderate amounts of focused air. The Heat Torch™ 075 offers over twice the air flow capacity of the Heat Torch™ 050. The Heat Torch™ 075 can be mounted in either a horizontal or vertical position and includes several inlet and exhaust fittings options.
- Heat Torch™ 075 will meet requirements for air flow ranging from 1.3 to 25 SCFM with power of 100 watts to 1000 watts (in 100 watts increments).
- Maximum air input temperature is 250° F (121° C) with 1300° F (704° C) maximum output temperature.
- Applications for Heat Torch™ 075 include staking, curing, drying, heat shrinking, sterilization, and adhesive activation.

### Wattage & Voltage Options

#### Mica Core (Max. Exhaust of 900° F):

120V, single phase, 0.2kW-.9kW  
 208V, single phase, 0.2kw-0.95kW  
 240V, single phase, 0.2kW-1.0kW

#### Ceramic Core (Max. Exhaust of 1300° F):

120V, single phase, 0.2kW-.9kW  
 208V, single phase, 0.2kW-1.0kW  
 240V, single phase, 0.2kW-1.0kW

### Other Options

Thermocouple Fitting  
 Thermocouple  
 Flexible Conduit

### Fitting Options

#### Inlet Fitting:

1/8F- 1/8" FNPT  
 1/4F- 1/4" FNPT  
 CB- Counterbore 1/2" O.D.

#### Exhaust Fitting:

1/4F- 1/4" FNPT  
 3/8F- 3/8" FNPT  
 NF- No Fitting  
 TE- 3/4" to 1/2" Reducing Adaptor

### Specifications

Category:	Inline Heaters, Process Heaters, Open Coil Heaters
Max. wattage:	1.0kW
Max. exhaust air temp.:	1300°F
Max. inlet air temp.:	250°F
Max. SCFM:	25
Max Allowable Pressure:	120 psig
Mounting:	Horizontal/Vertical
Leads:	20 gauge (12" long)
Heater Body:	Stainless Steel
Inlet Fitting:	Stainless Steel
Exhaust Fitting:	Stainless Steel



Wattage	Min. SCFM Req.
0.1kW	1.3
0.2kW	1.3
0.3kW	1.3
0.4kW	1.3
0.5kW	1.3
0.6kW	1.3
0.7kW	1.3
0.8kW	1.4
0.9kW	1.7
1.0kW	1.8

Airflow (SCFM)	Pressure Drop (psig)
1.3	0.10
2	0.20
3	0.45
4	0.80
6	1.8
8	3.2
10	5.0
15	11.3
20	20.0
25	31.3

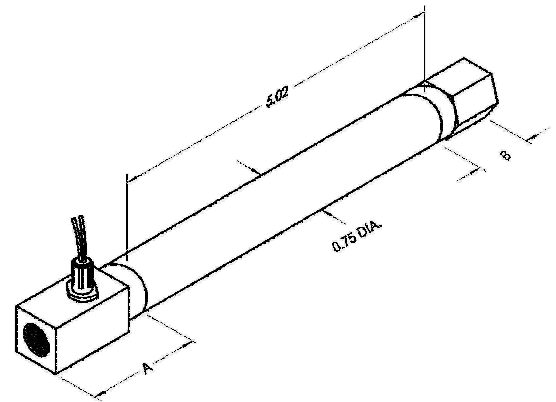

Inlet Fitting	Dim. A	Exhaust Fitting	Dim. B
1/8F	1.32	1/4F	0.85
1/4F	1.58	3/8F	0.85
CB	1.32	NF	0.04
		TE	0.16

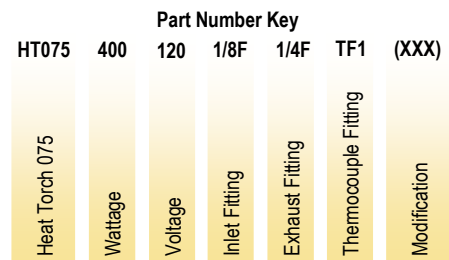

**SOUTHEAST THERMAL SYSTEMS**

WWW.SETHERMAL.COM

SALES@SEETHERMAL.COM

phone: 704-399-4248