

# QUARTZ TUBING OPTIONS

INFRARED HEATERS & COMPONENTS  
FROM SOLAR PRODUCTS, INC.

*ELEMENTS*

*END CAPS*

*TUBES*

*REFLECTORS*

*FITTINGS*

*TERMINATIONS*

# QUARTZ TUBING OPTIONS

## CLEAR TUBING

For most applications, clear tubing is the preferred choice. Clear quartz has a much higher transmission of IR energy than does translucent quartz. This translates into a higher radiant efficiency. Clear quartz allows for faster response time. Clear quartz generates a shorter wavelength than does translucent. Clear quartz is available in a greater quantity of diameter options. Clear quartz can operate at higher temperatures, namely up to 1800°F (982°C).

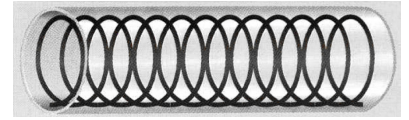

## TRANSLUCENT TUBING

The main advantages of translucent tubing is lower pricing, longer wavelength, and non-exposed heating element. Some applications prefer the aesthetics of a translucent tube because the heating element is concealed within the tube.

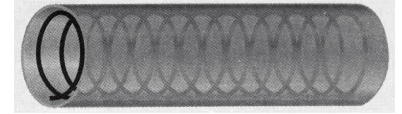

**TUBING DIAMETER** (3/8", 1/2", 5/8", 7/8", or 1" - clear) (3/8", 1/2", 5/8" - translucent) The tubing diameter is commonly determined by matching the existing tube diameter or based on the specifics of the tube design, namely the tube wattage, voltage, and heated tube length. The goal is to keep the coil watt density low for long tube life. Coil watt density should not be confused with watts per lineal inch, which is the total wattage divided by the heated length. Coil watt density is the watt density on the coil itself. Good design for long element life is achieved by having a low coil watt density. Sometimes this is accomplished by changing the tube voltage. Other times, the tube diameter is increased.

# HEATING ELEMENTS

## STANDARD

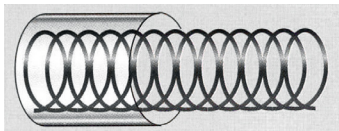

This heating element is a single precision wound resistance wire made of iron-chromium-aluminum. This coil has a typical long life expectancy of 10,000 hours. This element typically ramps up to temperature in 10 - 20 seconds depending on the tube design. The maximum watt density is 60 watts per lineal inch.

## MULTI-WOUND

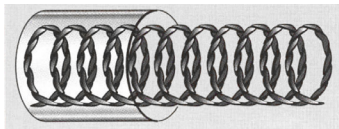

This patented heating element has two precision wound resistance wires made of iron-chromium-aluminum wire that are inter-twined. By reducing the wire mass, the time required for the element to get up to temperature is greatly reduced. The multi-wound element ramps up to operating temperature in 5 seconds. Actual time will depend on overall design of the tube. This coil has a typical life expectancy of 5,000 hours. The maximum watt density is 60 watts per lineal inch.

# REFLECTORS

## INTERNAL CERAMIC REFLECTOR

This patented reflector is a ceramic fiber refractory material that is machined into 1/2 of the inside diameter of the tube. This quartz tube design has a high radiant efficiency that does not change over time. Conventional tubes require external reflectors, which become dirty and inefficient over time. An internal reflector minimizes the time and expense of replacing external reflectors over time. This design is only available in 5/8" tubing.

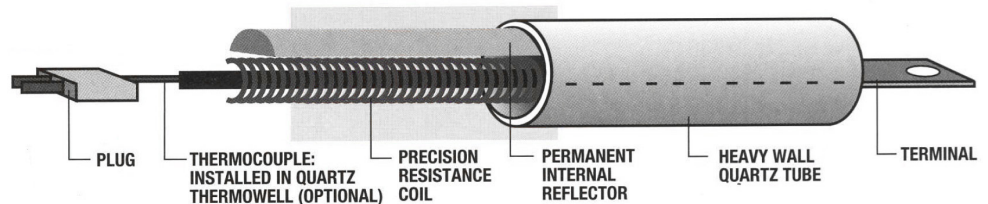

## GOLD REFLECTOR

This reflector is a patented process that applies gold to one side of the tube. Gold is a highly reflective material that directs the infrared energy at the process. It eliminates the need for an external reflector. The process does add considerable cost to the price of the tube.

## NO REFLECTOR

For new installations, a reflector makes good sense. But, if you are replacing tubes without reflectors, it is best to replace these elements with a similar design. Tubes with reflectors should not be mixed with non-reflector tubes.



## STRAIGHT FLAG TERMINAL WITH OVAL HOLE OR FORKED TERMINAL

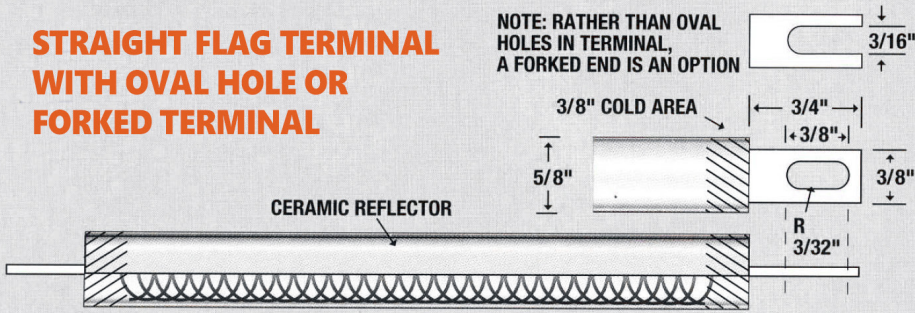

## MOUNTING BLOCK

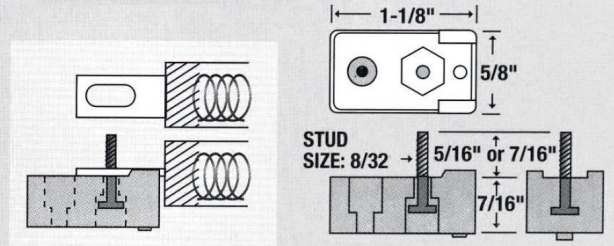

## 90 DEGREE FLAG TERMINAL WITH OVAL HOLE OR FORKED TERMINAL

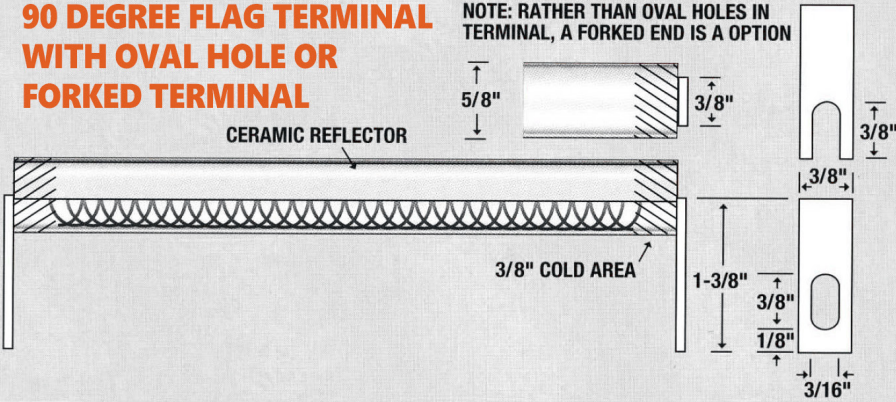

## OPTIONAL CERAMIC OVERCAP

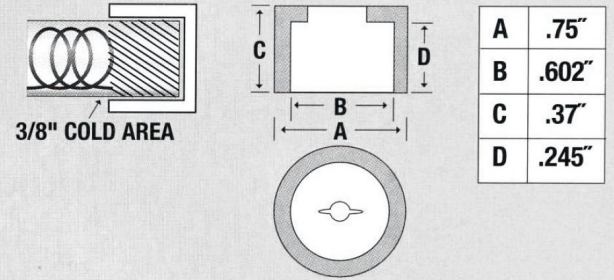

## CERAMIC OVERCAP AVAILABLE WITH STUD TERMINATION

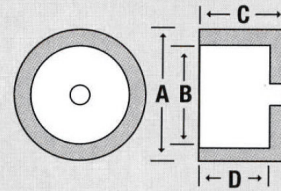
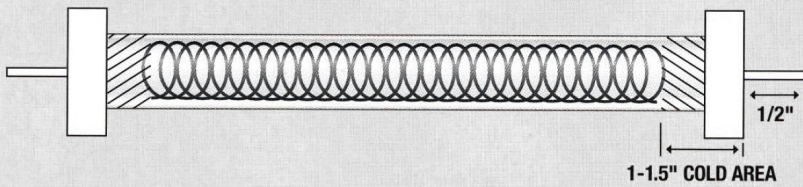

	3/8"	1/2"	5/8"
A	.690"	.75"	.925"
B	.436"	.522"	.67"
C	.50"	.432"	.5"
D	.376"	.3"	.375"

## TIPPED CERAMIC OVERCAP AVAILABLE WITH WIRE TERMINATIONS

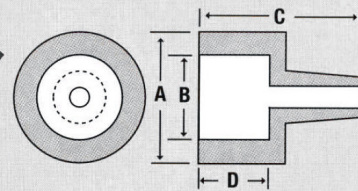
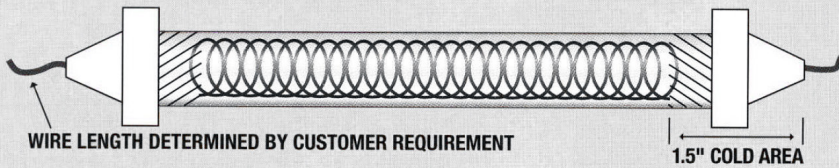

	3/8"	1/2"	5/8"	5/8"*
A	.623"	.748"	.875"	.925"
B	.420"	.537"	.675"	.670"
C	.702"	.695"	.695"	1.0"
D	.265"	.265"	.265"	.390"

\*HEAVY DUTY

## 90 DEGREE WIRE TERMINAL WITH LOOPED END

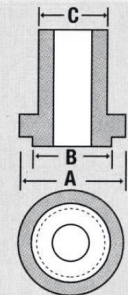
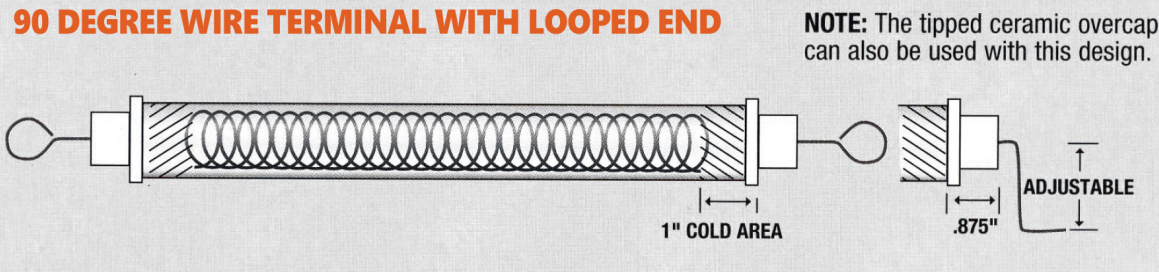

	1/2"	1"
A	.493"	1.05"
B	.365"	.79"
C	.285"	.285"
D	.508"	.885"

## QUICK DISCONNECT TERMINAL WITH CERAMIC INSERT

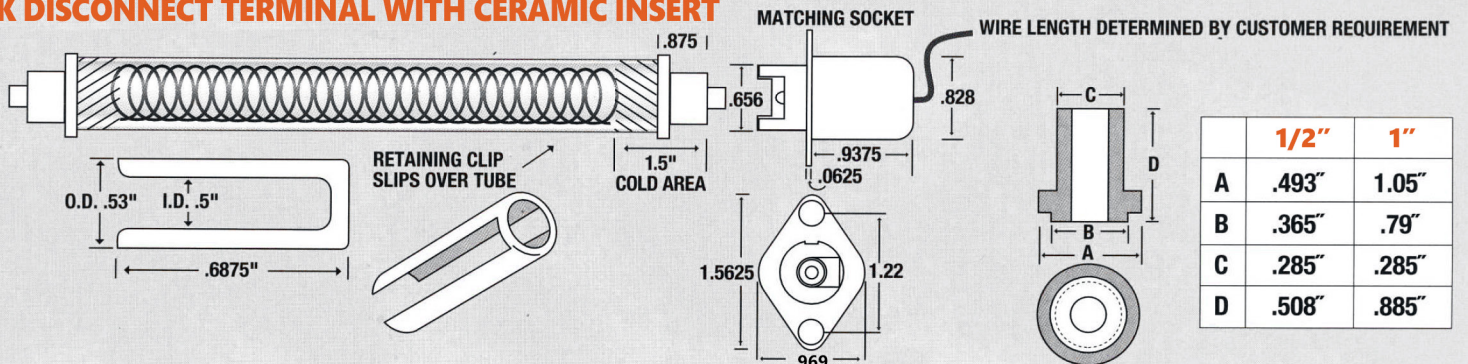

	1/2"	1"
A	.493"	1.05"
B	.365"	.79"
C	.285"	.285"
D	.508"	.885"



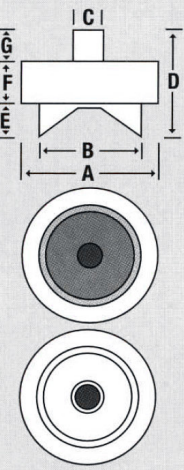

5/8"	
A	1.05"
B	.82"
C	.30"
D	.94"
E	.217"
F	.337"
G	.35"

### QUICK DISCONNECT TERMINAL WITH POSITIONING TAB

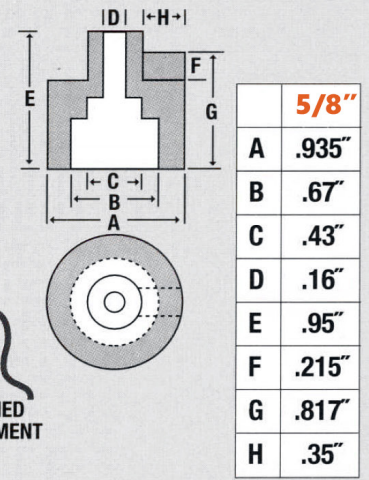
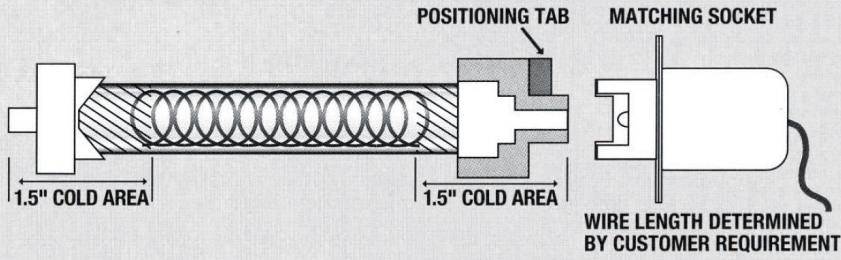

5/8"	
A	.935"
B	.67"
C	.43"
D	.16"
E	.95"
F	.215"
G	.817"
H	.35"

### QUICK DISCONNECT TERMINAL WITH EXTENDED TIP

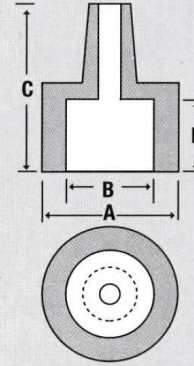
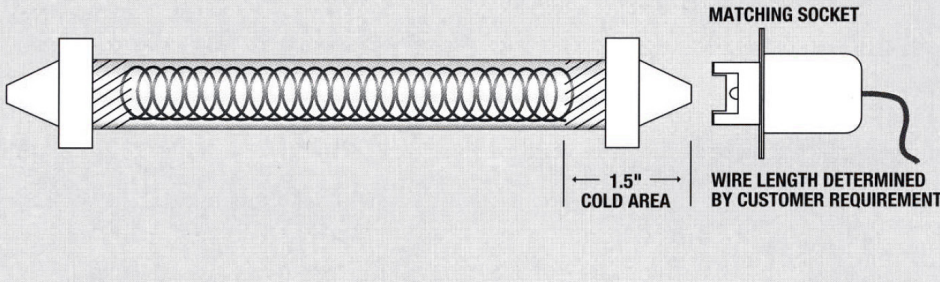

### TIPPED CERAMIC OVERCAP

	3/8"	1/2"	5/8"
A	.623"	.748"	.875"
B	.420"	.537"	.675"
C	.702"	.695"	.695"
D	.265"	.265"	.265"

### CERAMIC LONG BODY TERMINAL WITH FLEXIBLE WIRE LEADS

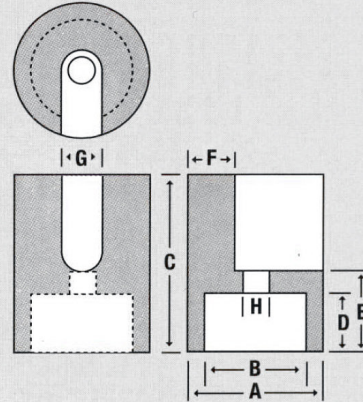
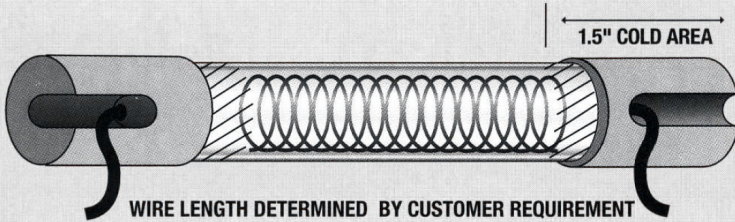

1/2"	
A	.835"
B	.58"
C	1.02"
D	.25"
E	.43"
F	.295"
G	.260"
H	.150"

### CERAMIC BODY WITH STEP FOR POSITIONING THE TUBE AVAILABLE WITH STUD, WIRE, OR SPADE TYPE TERMINAL

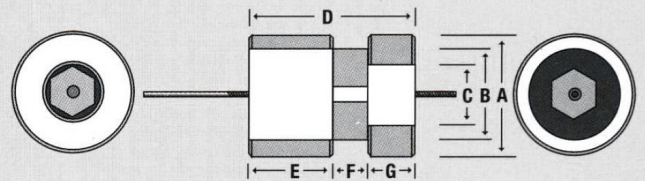
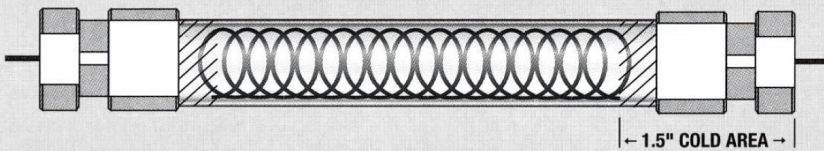

1/2"	A	B	C	D	E	F	G
	.755"	.545"	.43"	1.00"	.475"	.195"	.336"

### SINGLE END TERMINAL DESIGN

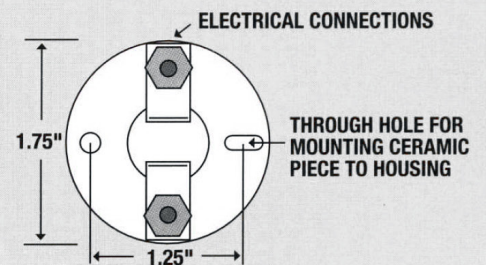
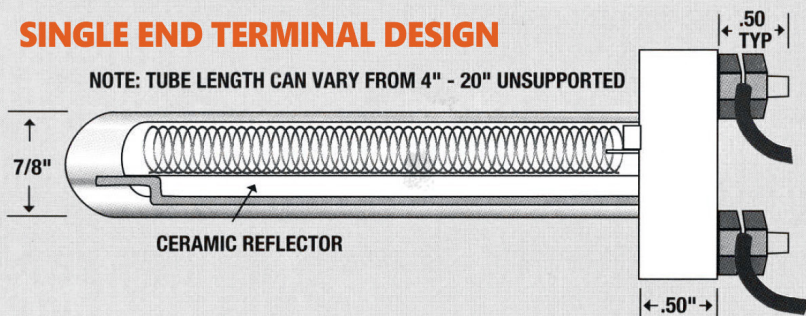



# WHY SOLAR PRODUCTS QUARTZ TUBES?

Solar Products has been manufacturing infrared heaters for over 60 years. That experience ensures that you get the right heater for your application, the first time. With so many quartz tubing options available, we can match an existing tube and/or provide a new tube design that maximizes your process.

## TRANSLUCENT TUBING

The main advantages of translucent tubing is lower pricing, longer wavelength, and non-exposed heating element. Some applications prefer the aesthetics of a translucent tube because the heating element is concealed within the tube.

**TUBING DIAMETER** (3/8", 1/2", 5/8", 7/8", or 1" - clear) (3/8", 1/2", 5/8" - translucent) The tubing diameter is commonly determined by matching the existing tube diameter or based on the specifics of the tube design, namely the tube wattage, voltage, and heated tube length. The goal is to keep the coil watt density low for long tube life. Coil watt density should not be confused with watts per lineal inch, which is the total wattage divided by the heated length. Coil watt density is the watt density on the coil itself. Good design for long element life is achieved by having a low coil watt density. Sometimes this is accomplished by changing the tube voltage. Other times, the tube diameter is increased.

## SOLAR PRODUCTS OFFERS:

- Clear or translucent tubing
- 3/8", 1/2", 5/8", 7/8", or 1" tube diameters available
- Internal reflectors, gold back reflectors, or no reflectors
- Snap-in, stud, wire, straight terminal, and many other connection options
- Single or standard dual-ended terminals
- Long life or fast response heating elements
- Quartz tube lengths exceeding 90"
- Complete assemblies

With so many tube options, how do you choose which one is right for your application? The many options available and the related advantages will be reviewed throughout this brochure.

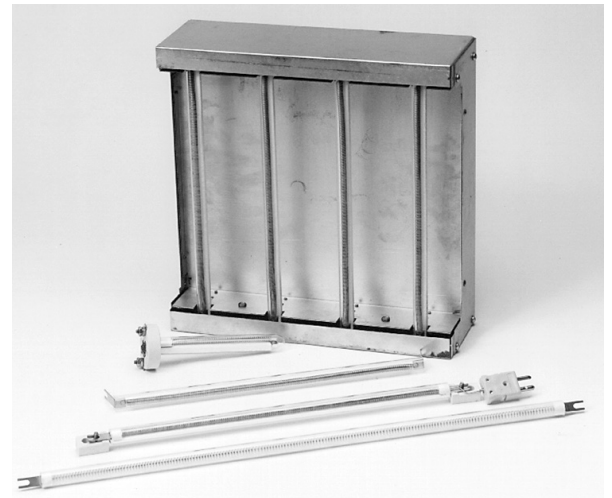

## TUBES VERSUS LAMPS

Often times quartz tubes and quartz lamps are thought to be interchangeable terms. This is not the case. Following is a chart comparing the differences between the two infrared heaters:

Comparative Points	Quartz Lamps (T3)	Quartz Tubes
Color Sensitivity - the effect product color has on heating cycle times	Yes (Example: white colored products will take longer to heat than black)	Minimal
Wavelength Type of element	Primarily short wave Tungsten filament in vacuum	Primarily medium wave Iron-Chromium-Aluminum element (Nickel-Chromium is also used)
Power output per tube	(Usually an inert gas, such as halogen is used)	Up to 60 watts/lineal inch Up to 60 watts/sq inch
Power output over a given area	Up to 200 watts/lineal inch	Reasonably priced zero cross SCR or SSR
Power switch device	Up to 60 watts/sq inch is common	Up to temperature in 5-30 seconds, depending on the design
Temperature response	Expensive phase angle SCR	7% initial current
Inrush current	Up to temperature in 2-4 seconds Up to color in 1-2 seconds	No cooling requirements
Terminal cooling requirements	700% - 1000%	Custom manufactured in length, wattage, voltage, and termination
Design flexibility	Air or water cooling required Standard sizes available	10,000 Hours
Typical life expectancy	< 5,000 Hours	

## ABOUT SOLAR PRODUCTS

In 1956, Richard Eck, the founder, had a few good ideas about making a better infrared heater. Today, over 60 years later, that philosophy continues to radiate throughout Solar Products. Many ideas and several patents later, Solar Products has become the largest supplier of medium wave infrared heaters in the US market. At Solar Products, we don't build systems, we manufacture infrared heaters. Maybe that's why we've grown to be the largest supplier of infrared heaters in the industry...by staying focused.

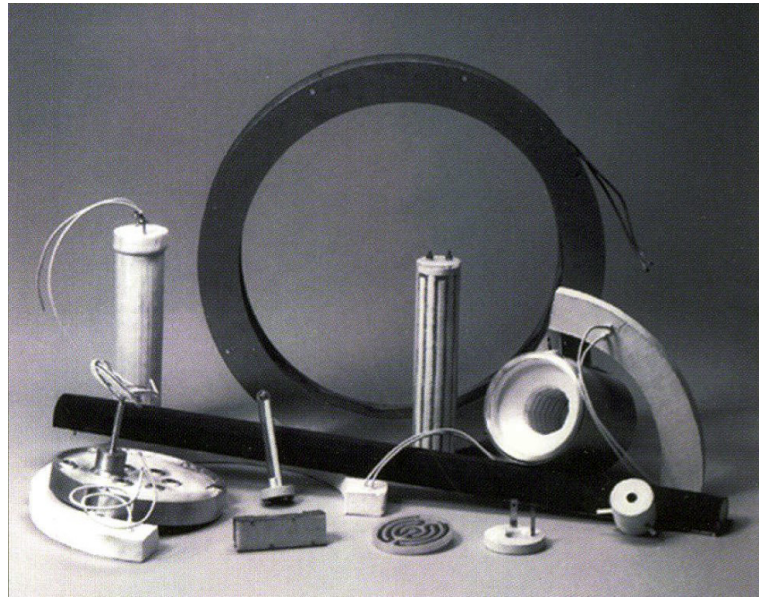

Specialty Heaters

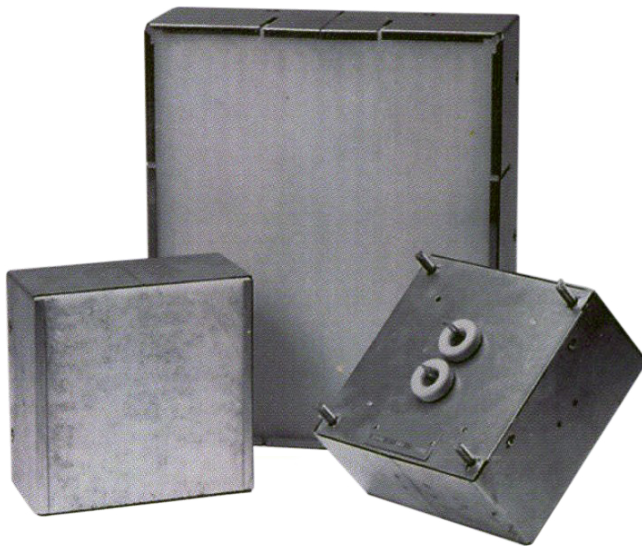

Q-Series

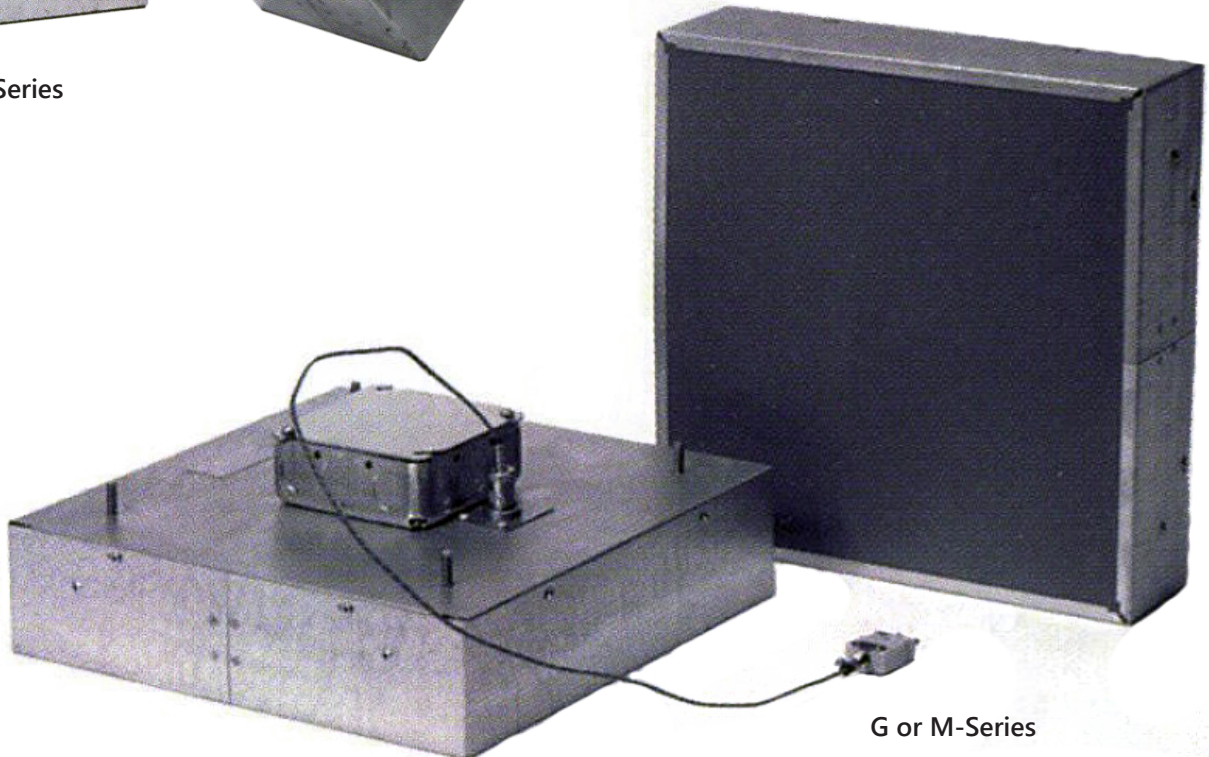

G or M-Series



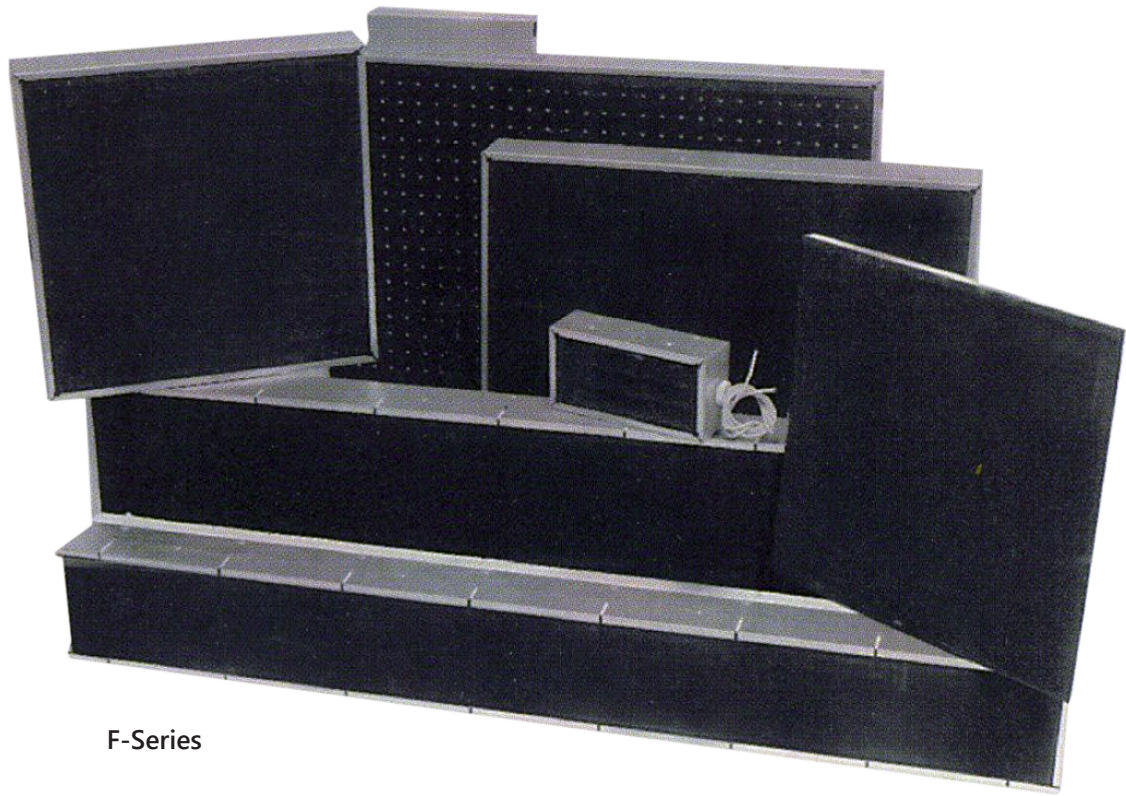

F-Series



Furnace Technology