

Company Name: _____
 Customer Name: _____
 Address: _____
 Phone: _____
 Email: _____



**SOUTHEAST
 THERMAL SYSTEMS**
WWW.SETHERMAL.COM SALES@SEETHERMAL.COM phone: 704-399-4248

APPLICATION:

Describe in Detail: _____

Air or Immersion _____
 Max Load Temp: _____
 Quantity: _____

SPECIFICATIONS:

Type: Straight Finned Single Ended
 Sheath Material: _____
 Diameter _____ Fin Dia (if app) _____
 Overall Sheath Length _____
 Cold Section: 1st end _____ 2nd end _____
 Watts _____ Volts _____
 UL _____ cUL _____ CSA _____ CE _____
 Termination Type: _____

Mounting:
 Bulkhead Fittings _____ Material _____
 Flange Type _____

Mounting Collar: _____

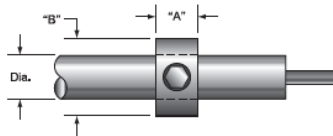

Locator Washer: _____
 Specify Length

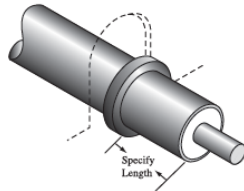

Mounting Bracket:

W= _____
 L = _____
 H= _____
 Holes:
 Dia: _____
 G: _____
 F: _____

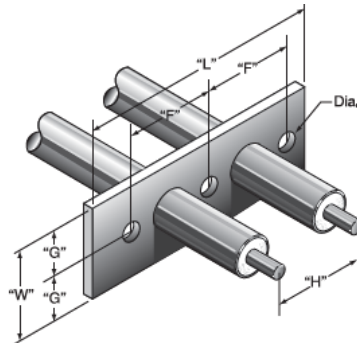

MOISTURE SEALS:

Moisture Seals: None _____
 Optional:
 Silicone Resin Seal:
 conformal coating _____ Silicone Oil _____
 Room Temperature Vulcanizing:
 302°F (150°C) _____ 392°F (200°C) _____
 Epoxy Resin Seal:
 194°F(90°C) _____ 266°F(130°C) _____
 392°F (200°C) _____

SPECIFICATIONS:

(for Incoloy and Stainless Steel Elements only)
 Passivation: _____ Bright Annealing: _____
 Electro-Polishing: _____
 Other: _____

SPECIFICATIONS:

Standard Formation Code: _____
 Specify Letters & Corresponding Dimensions Below:
 Straight: A _____ B _____ C _____ D _____

U Type 1: A _____ B _____ C _____ D _____ E _____

U Type 2: A _____ B _____ C _____ D _____ E _____ G _____

W Type 1: A _____ B _____ C _____ D _____ E _____ F _____

W Type 2: A _____ B _____ C _____ D _____ E _____ G _____
 F _____

Number of Bends if known

Single/Multiple: _____ Plane: _____
 Coil/Turns: _____ Dia: _____
 Circle Full: _____ Dia: _____ Partial _____
 Degree _____

Describe if Custom _____

Straight Finned Tubular Heater Type

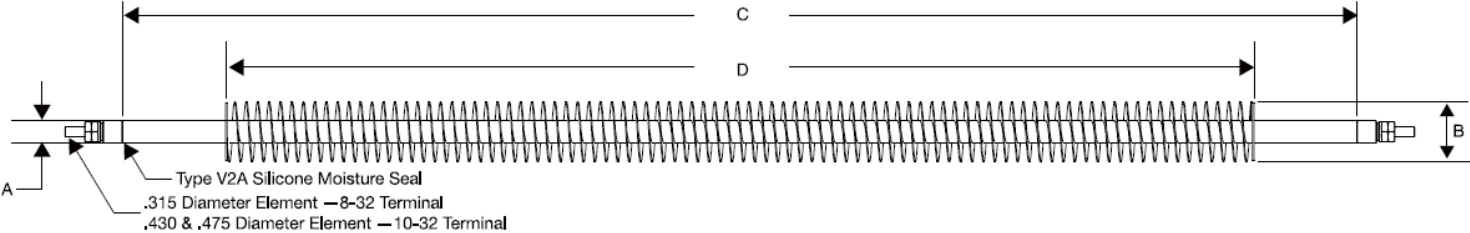

U-Bent Finned Tubular Heater Type 1

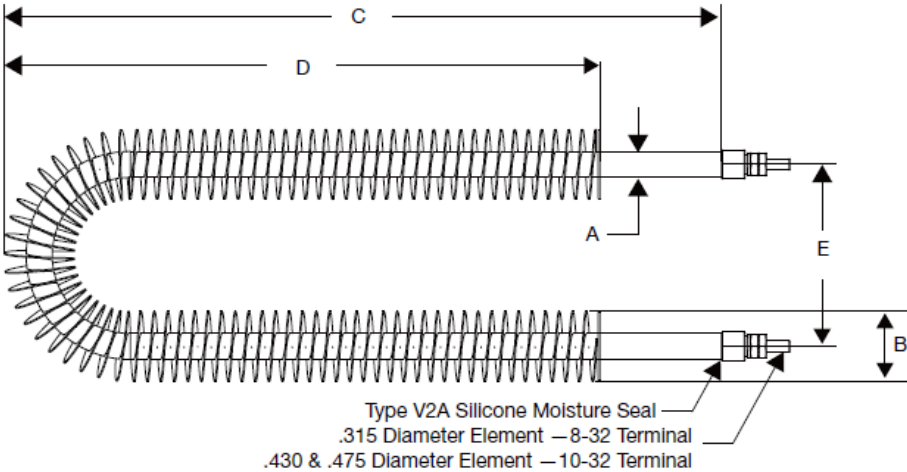

U-Bent Finned Tubular Heater Type 2

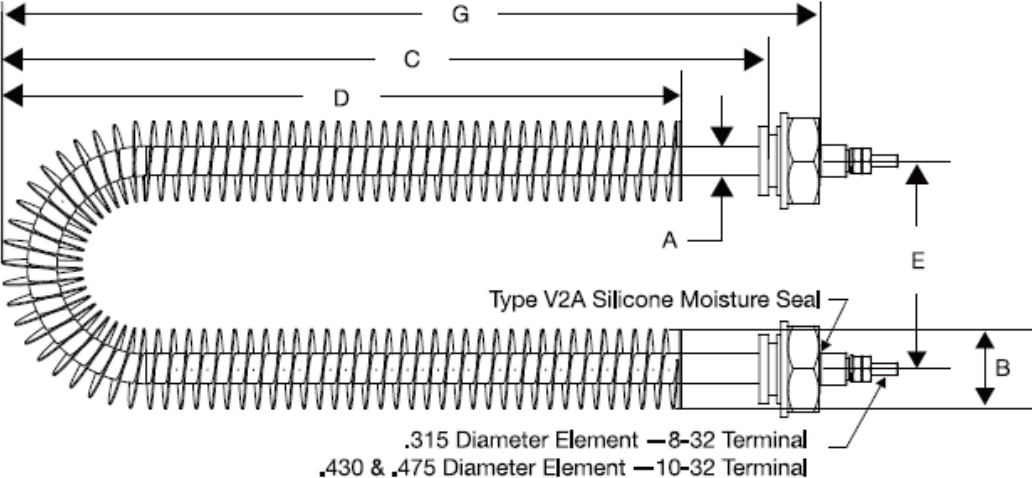

W-Bent Finned Tubular Heater Type 1

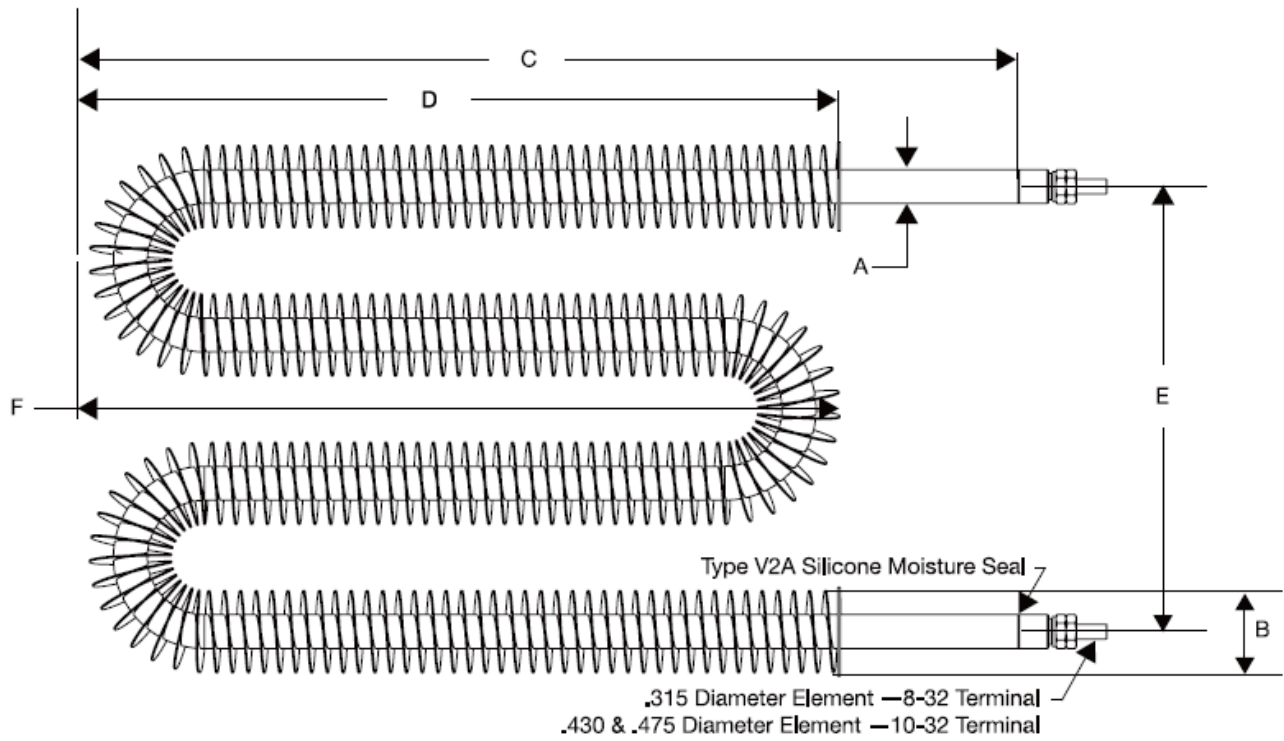

W-Bent Finned Tubular Heater Type 2

