



STANDARD 200mm & 300mm Standard Aluminum Platen Heaters

QUICK SOLUTIONS FOR WAFER FABRICATION

Customers can now save thousands of dollars with off-the-shelf designs since there are no additional costs for engineering, tooling or casting mold creation.

This platen heater design is ideal for prototype machine trials or engineering experiments as well as temporary repairs until custom heaters can be manufactured. CAS platen heaters provide a complete turnkey solution and are available in anodized finish, or in bare machined

aluminum 356 with optional add-on features. The stock anodized cast aluminum platen heaters are complete, ready to install parts and are available for shipment within one business day.

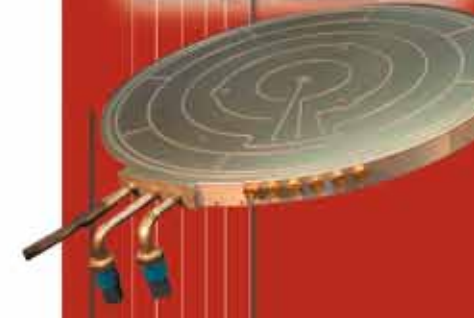

APPLICATIONS

Semiconductor Processing

Semiconductor research and development

FEATURES AND BENEFITS

Stock delivery

WR200-2A and WR300-2A ship within one business day to reduce down time
Assures a cost effective option for 200 and 300 mm wafer processing

World class performance

"Cast-in" reliability assures long product life
Operating temperatures up to 752°F (400°C) for a wide range of process applications
Surface temperature uniformity of $\pm 0.3\%$ of set point assures wafer processing accuracy

SPECIFICATIONS

Standard Features (All Models)

- Material: Aluminum alloy 356
- Surface Flatness: < 0.0005 in. (0.013 mm)
- Surface Temperature Uniformity: $\pm 0.3\%$ of set point based on measurements at laboratory ambient conditions
- Cleaning: Ultrasonic wash followed by IPA wipe down
- Hard Anodize Thickness: 0.002 in. (0.05 mm) per MIL-A-8525, Type III, Class I (models WR200-2A and WR300-2A only)

MODEL WR200-2A

200mm Anodized Platen Heater

DIMENSIONS

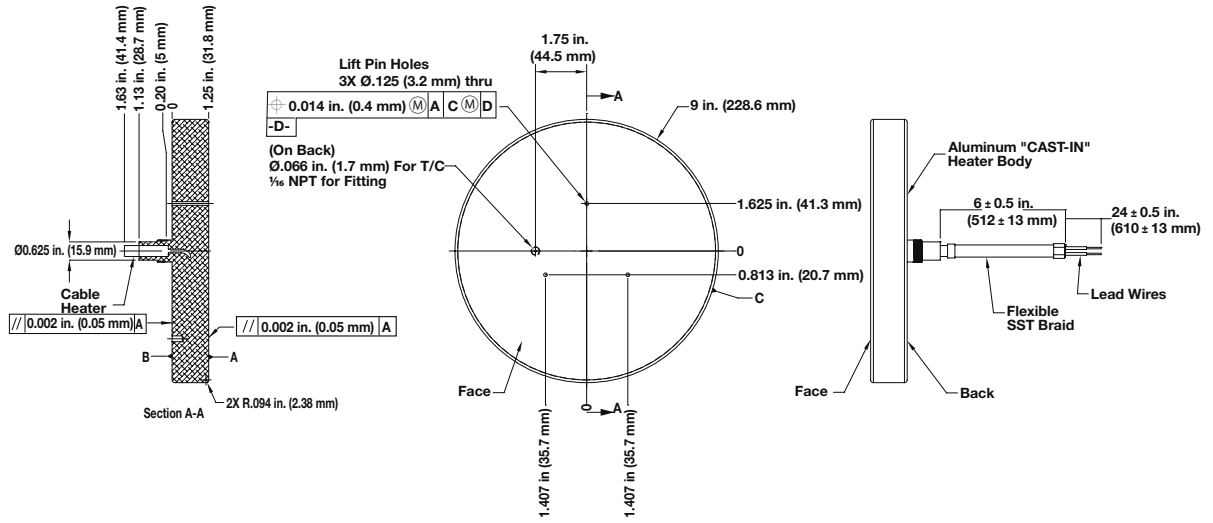

SPECIFICATIONS

MODEL WR200-2A

MODEL WR200-2B

Diameter: 9 in. (228.6 mm)

Thickness: 1.25 in. (31.75 mm)

(3X) Lift Pin Holes diameter 0.125 in. (3.2mm) equally spaced 120° on 3.25 in. (82.55 mm) perfect circle diameter

(1X) Thermocouple hole diameter 0.066 in. (1.68 mm) with 1/16 NPT tap for fitting

"Cast-in" cable heater rated 1681 W at 208V (or 2241 W when operated at 240V)

ORDERING INFORMATION

WR200-2A Series Platen With Hardcoat Anodize Finish: Reference drawing above

Rating: Typical 208V, 1681 W, Maximum 240V, 2241 W, Part is ultrasonic washed followed by IPA wipe down prior to packaging, Delivery 6-8 wks

Item:

No thermocouple included
 Thermocouple, Type K, 6 in. (152 mm) sheath + fitting
 Thermocouple, Type J, 6 in. (152 mm) sheath + fitting
 Thermocouple, Type K, 12 in. (305 mm) sheath + fitting
 Thermocouple, Type J, 12 in. (305 mm) sheath + fitting

Code Number:

WR200-2A
WR200-3A
WR200-4A
WR200-5A
WR200-6A

MODEL WR200-2B

200mm Bare Machined Aluminum Platen Heater

ORDERING INFORMATION

WR200-2B Series Platen With Bare Machined Aluminum Finish: Reference drawing above

Rating: Typical 208V, 1681 W, Maximum 240V, 2241 W, Part is ultrasonic washed followed by IPA wipe down prior to packaging, Delivery 4-6 wks

Item:

No thermocouple included
 Thermocouple, Type K, 6 in. (152 mm) sheath + fitting
 Thermocouple, Type J, 6 in. (152 mm) sheath + fitting
 Thermocouple, Type K, 12 in. (305 mm) sheath + fitting
 Thermocouple, Type J, 12 in. (305 mm) sheath + fitting

Code Number:

WR200-2B
WR200-3B
WR200-4B
WR200-5B
WR200-6B

