

CAST-X 2000

Circulation Heater

CAST-X 2000 is a very versatile heater, with multiple housing, standoff, control and enclosure options.



Designed and manufactured by Cast Aluminum Solutions (CAS), CAST-X Circulation Heaters are engineered using the latest thermal modeling and finite element analysis technology. CAST-X heaters feature low-watt-density heating elements cast into aluminum bodies which also contain the helical-coiled stainless steel flowpath tubes.

The media is sequestered in these tubes, never touching the heating elements: a critical safety benefit, especially when heating explosive or sensitive media. All CAST-X units are capable of heating liquids and gases alike.

CAST-X heaters are self-draining, for safety and cleanliness. With compact, non-welded bodies, plus NEMA & ATEX enclosures, CAST-X units are small-footprint, high-output heaters that meet the needs of high-purity processes, flammable operations, and your most critical heating applications.

APPLICATIONS:

- Compressor Condensate Evaporation
- Semiconductor Solvent Applications
- DI Water Heating
- Fuel and Oil Pre-Heating
- Nitrogen Gas Heating
- Two-Part Urethane and Foam Systems
- Anodizing / Plating Pre-Wash Applications

SPECIFICATIONS:

- Power:
 - 1 kW Total to 6 kW Total
 - Voltage Range: 120 - 480 V
 - Max Line Current: 25 A per circuit
- Tubing:
 - .500" OD (1/2") (12.7 mm)
 - .065" Wall (1.7 mm)
 - Overall Process Tube Length: 150" (3810 mm)
 - 316L Stainless Steel (standard)
 - Inconel (optional upgrade)
 - Passivated or Electro-Polished (optional upgrades)
- Max Pressure: 5100 psi (351 bar)
- Enclosures:
 - NEMA 1 (general-purpose/dust-proof)*
 - NEMA 4 (moisture-resistant)*
 - NEMA 7 (explosion-proof)
 - Available with Standard or Standoff Design
- Max Working Temperatures:
 - NEMA 1 (dust-proof/general-purpose): 482°F (250°C)
with standoff: 662°F (350°C)
with t-stat (w/ or w/o standoff): 250°F (121°C)
 - NEMA 4 (moisture-resistant): 350°F (175°C)
with standoff: 662°F (350°C)
 - NEMA 7 (explosion-proof): 482°F (250°C)

Published temperatures are for housing at 12 o'clock position; higher temps may be possible at 6 o'clock position. See factory for details.

- Sensors:
 - K or J Type Thermocouples Standard
 - Snap-Action High-Limit Thermostat
 - Process and High-Limit Thermocouples
- Available Accessories:
 - Insulating Jacket
 - Compression Fittings

FEATURES & BENEFITS:

- SS 316L Fluid Path is Separate from Heating Elements
(allows safe heating of sensitive materials and prevents contamination)
- Low Ownership Cost: Minimal Maintenance & Downtime
- Self-Draining & Non-Welded (reduces contamination)
- Food, Medical & Semiconductor Application Compatible
- Available with Cost-Effective Over-Temperature Protection
- Compatible with High Pressure Applications
- Standoff Housings Available (for higher temperatures)

CAST-X 2000 Circulation Heater

GENERAL-PURPOSE (NEMA 1) ENCLOSURE

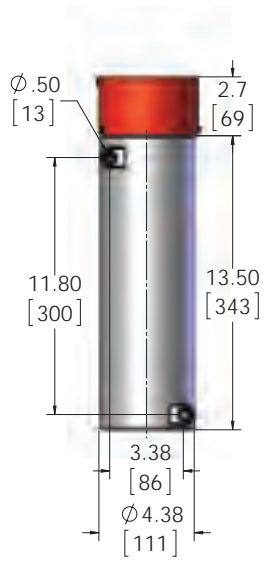

GENERAL-PURPOSE (NEMA 1) WITH THERMOSTAT



GENERAL-PURPOSE (NEMA 1) WITH STANDOFF, NO THERMOSTAT

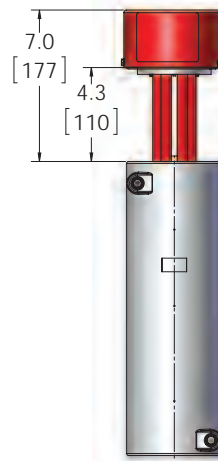

GENERAL-PURPOSE (NEMA 1) WITH STANDOFF & THERMOSTAT

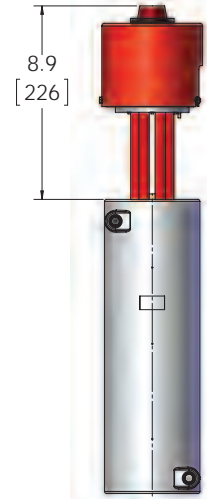

CAST-X 2000 Heating Profile: Delta-T Water

(Process Fluid = Water @ 42°F / 5.6°C Inlet Temp, Single Pass, 100% Power, Set Point 752°F / 400°C)

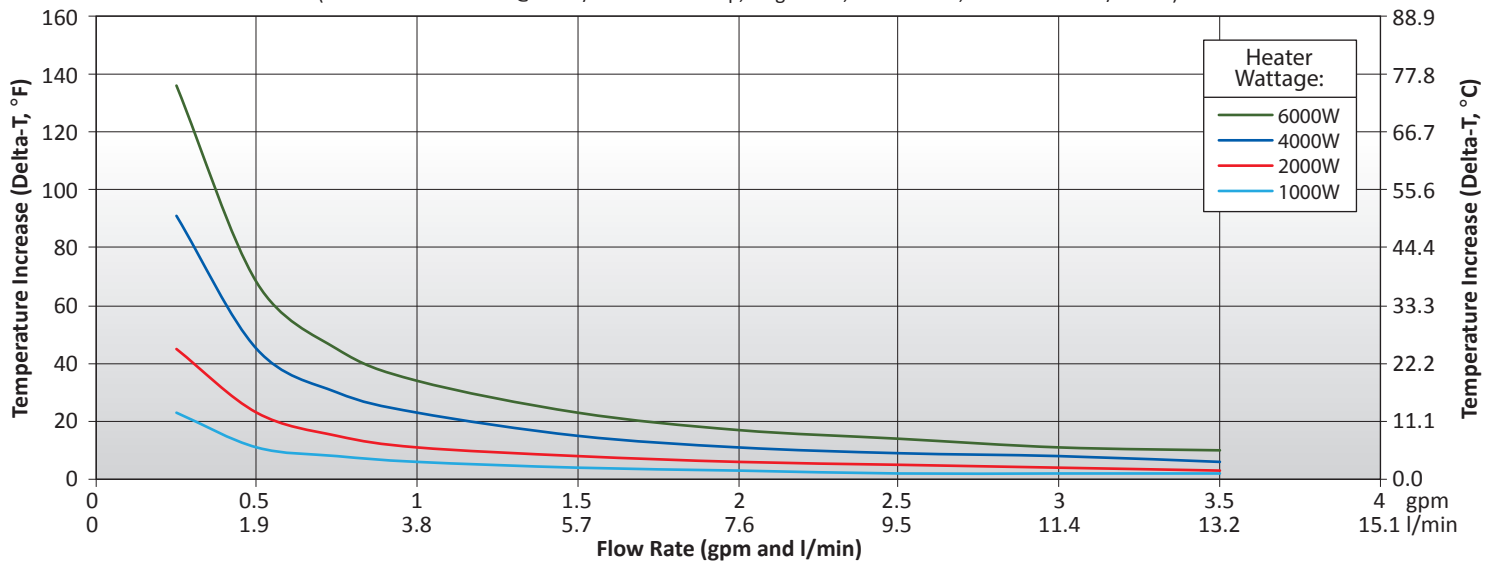

CAST-X 2000 Pressure Drop Profile: Delta-P Water

(Process Fluid = Water. Change in Pressure from Inlet to Outlet, Single Pass)

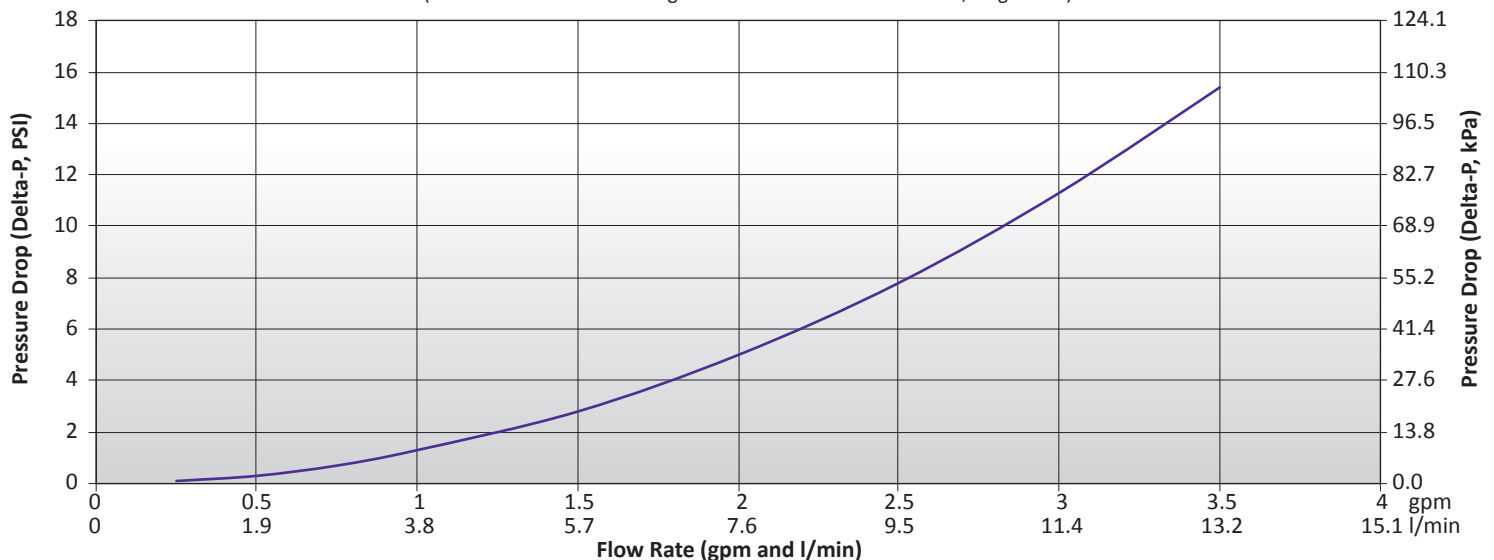

**MOISTURE-RESISTANT (NEMA 4)
WITH OR WITHOUT THERMOSTAT**

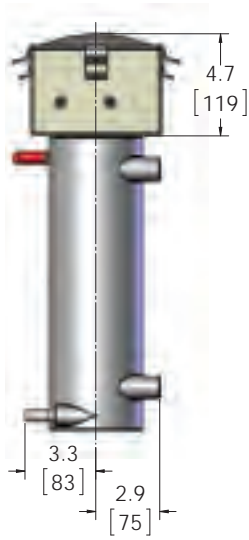

**MOISTURE-RESISTANT (NEMA 4) WITH
STANDOFF, WITH OR W/O THERMOSTAT**

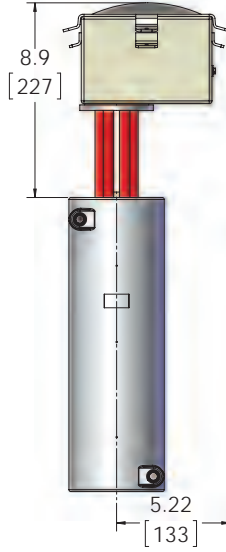

EXPLOSION-PROOF (NEMA 7)

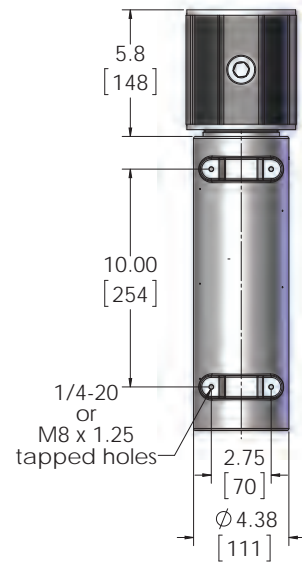

CAST-X 2000 Heating Profile: Delta-T Air

(Process Fluid = Air @ 100 psi (689 kPa), 70.7°F / 21.5°C, Single Pass, Set Point 752°F / 400°C)

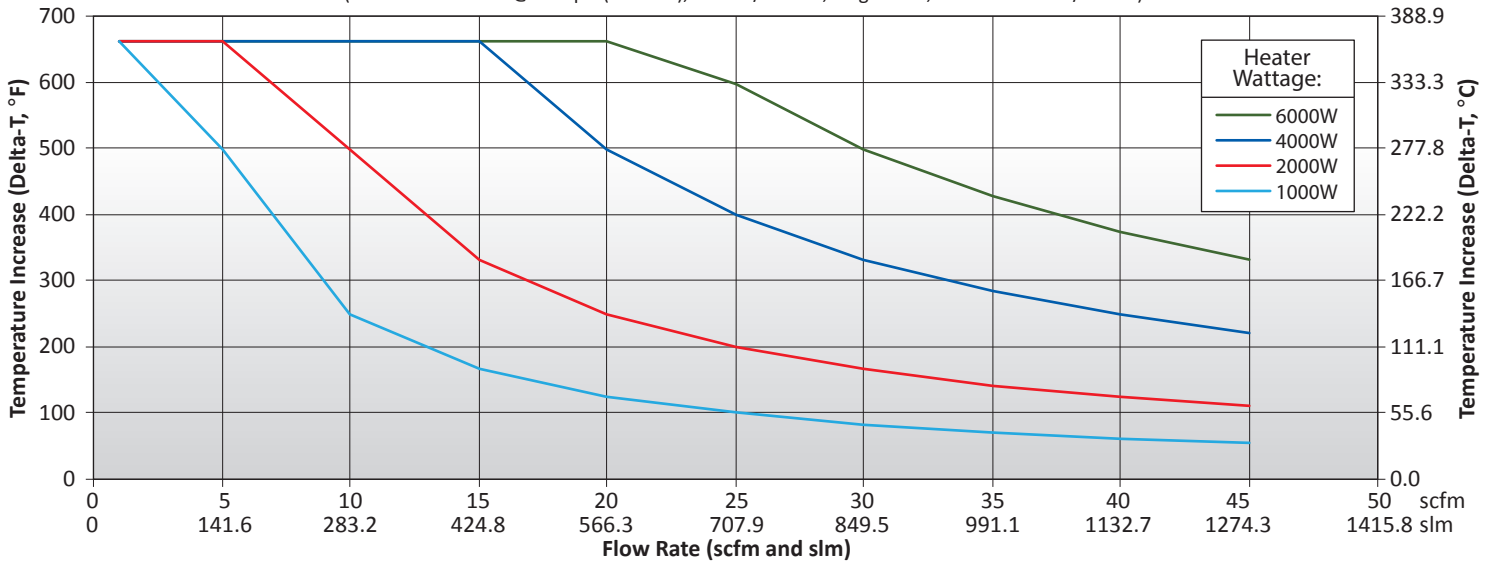

CAST-X 2000 Heating Profile: Delta-P Air

(Process Fluid = Air @ 100 psi (689 kPa), 70.7°F / 21.5°C, Single Pass, Set Point 752°F / 400°C)

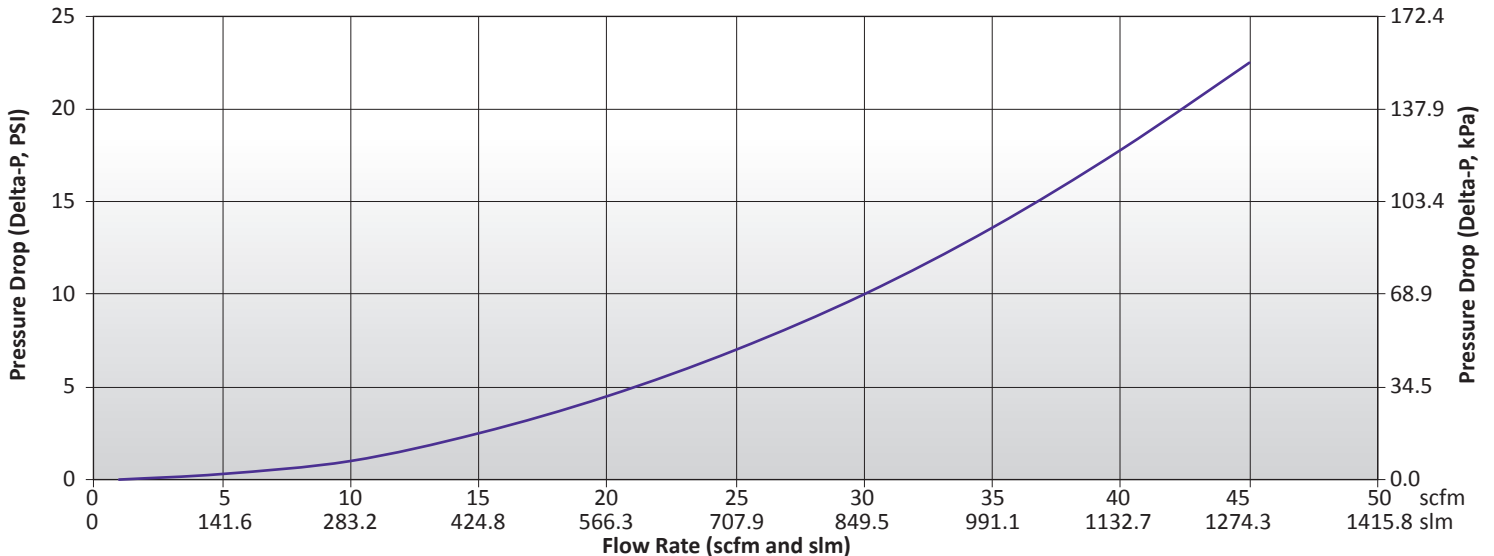

BX13J4G AAAA-BBCC-D

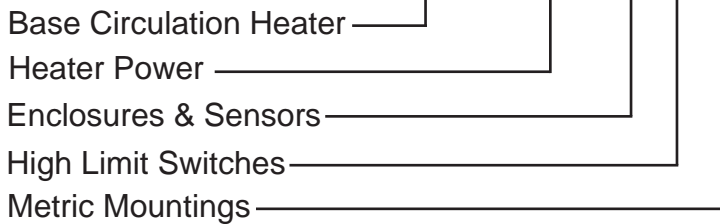

Building a CAST-X 2000 Part Number

Use the graphs below to build your CAST-X 2000. Assigning numbers for sections AAAA, BB and CC.
 If you need metric mountings, assign "M" to section D.
 If metric mounts are not required, leave section D blank.
 For assistance, contact CAS directly.

VOLTAGE, POWER, CIRCUIT TYPE – STANDARD-MOUNTED ENCLOSURE OPTIONS				
<i>The CAST-X 2000 is available with both standard or standoff designs. Volts refers to line volts (VL). Amps refers to line current (IL).</i>				
Section "AAAA"	Circuit Type (all are single circuit)	Volts (V)	Watts (kW)	Amps (A)
300A	Three Phase Delta	480	6.0	7.2
		440	5.0	6.6
		415	4.5	6.3
		400	4.2	6.0
		380	3.8	5.7
		240	1.5	3.6
		230	1.4	3.5
		220	1.3	3.3
300B	Three Phase Wye	208	1.1	3.1
		575	2.9	2.9
		480	2.0	2.4
		415	1.5	2.1
		400	1.4	2.0
		380	1.2	1.9
		240	0.5	1.2
		230	0.4	1.2
300C	Single Phase	220	0.4	1.1
		208	0.3	1.1
		480	6.0	12.5
		415	4.5	10.8
		400	4.2	10.4
		380	3.8	9.9
		347	3.1	9.0
		240	1.5	6.3
300D	Single Phase	230	1.4	6.0
		220	1.2	5.7
		208	1.1	5.4
		120	0.4	3.1
		480	4.0	8.3
		415	3.0	7.2
		400	2.8	6.9
		380	2.5	6.6
300E	Single Phase	347	2.1	6.0
		240	1.0	4.2
		230	0.9	4.0
		220	0.8	3.8
		208	0.7	3.6
		120	0.3	2.1
		480	2.0	4.2
		415	1.5	3.6
300E	Single Phase	400	1.4	3.5
		380	1.2	2.3
		347	1.0	3.0
		240	0.5	2.1
		230	0.4	2.0
		220	0.4	1.9
		208	0.3	1.8
		120	0.1	1.0

300F	Three Phase Delta	240	6.0	14.5
		230	5.5	13.8
		220	5.0	13.2
		208	4.5	12.5
300G	Three Phase Wye	415	6.0	8.3
		400	5.5	8.0
		380	5.0	7.6
		240	2.0	4.8
300H	Single Phase	208	1.5	4.2
		240	6.0	25
		230	5.5	24
		220	5.0	22.9
300J	Single Phase	208	4.5	21.7
		120	1.5	12.5
		240	4.0	16.7
		230	3.7	16
300K	Single Phase	220	3.4	15.3
		208	3.0	14.4
		120	1.0	8.3
		240	2.0	8.3
300L	Single Phase	230	1.8	8
		220	1.7	7.6
		208	1.5	7.2
		120	0.5	4.2
300M	Single Phase	240	1.5 Same as 300C	6.3
300N	Single Phase	240	1.0 Same as 300D	4.2
300O	Single Phase	120	1.5 Same as 300H	12.5
300P	Single Phase	120	1.0 Same as 300J	8.3
300Q	Three Phase Delta	120	4.5 Same as 300J	8.3
300R	Three Phase Delta	208	4.5 Same as 300F	12.5
300S	Three Phase Wye	208	1.5 Same As 300G	4.2
300T	Single Phase	208	4.5 Same as 300H	21.7
300U	Single Phase	208	3.0 Same as 300J	14.4
300V	Single Phase	208	1.5 Same as 300K	7.2

VOLTAGE, POWER, CIRCUIT TYPE – STANDOFF-MOUNTED ENCLOSURE OPTIONS				
<i>The CAST-X 2000 is available with both standard or standoff designs. Volts refers to line volts (VL). Amps refers to line current (IL).</i>				
Section "AAAA"	Circuit Type (all are single circuit)	Volts (V)	Watts (kW)	Amps (A)
30SA	Three Phase Delta	480	6.0	7.2
		440	5.0	6.6
		415	4.5	6.3
		400	4.2	6.0
		380	3.8	5.7
		240	1.5	3.6
		230	1.4	3.5
		220	1.3	3.3
30SB	Three Phase Wye	208	1.1	3.1
		575	2.9	2.9
		480	2.0	2.4
		415	1.5	2.1
		400	1.4	2.0
		380	1.2	1.9
		240	0.5	1.2
		230	0.4	1.2
30SC	Single Phase	220	0.4	1.1
		208	0.3	1.1
		480	6.0	12.5
		415	4.5	10.8
		400	4.2	10.4
		380	3.8	9.9
		347	3.1	9
		240	1.5	6.3
30SD	Single Phase	230	1.4	6.0
		220	1.2	5.7
		208	1.1	5.4
		120	0.4	3.1
		480	4.0	8.3
		415	3.0	7.2
		400	2.8	6.9
		380	2.5	6.6
30SE	Single Phase	347	2.1	6.0
		240	1.0	4.2
		230	0.9	4.0
		220	0.8	3.8
		208	0.7	3.6
		120	0.3	2.1
		480	2.0	4.2
		415	1.5	3.6
30SF	Three Phase Delta	400	1.4	3.5
		380	1.2	2.3
		347	1.0	3.0
		240	0.5	2.1
30SG	Three Phase Wye	230	0.4	2.0
		220	0.4	1.9
		208	0.3	1.8
		120	0.1	1.0
30SH	Single Phase	240	6.0	14.5
		230	5.5	13.8
		220	5.0	13.2
		208	4.5	12.5
30SH	Single Phase	415	6.0	8.3
		400	5.5	8.0
		380	5.0	7.6
		240	2.0	4.8
30SH	Single Phase	208	1.5	4.2
		240	6.0	25
		230	5.5	24
		220	5.0	22.9
30SH	Single Phase	208	4.5	21.7
		120	1.5	12.5

30SJ	Single Phase	240	4.0	16.7
		230	3.7	16
		220	3.4	15.3
		208	3.0	14.4
		120	1.0	8.3
30SK	Single Phase	240	2.0	8.3
		230	1.8	8.0
		220	1.7	7.6
		208	1.5	7.2
30SL	Single Phase	240	1.5	6.3
			Same as 300C	
30SM	Single Phase	240	1.0	4.2
			Same as 300D	
30SN	Single Phase	120	1.5	12.5
			Same as 300H	
30SP	Single Phase	120	1.0	8.3
			Same as 300J	
30SQ	Three Phase Delta	208	4.5	12.5
			Same as 300F	
30SR	Three Phase Wye	208	1.5	4.2
			Same As 300G	
30SS	Single Phase	208	4.5	21.7
			Same as 300H	
30ST	Single Phase	208	3.0	14.4
			Same as 300J	
30SU	Single Phase	208	1.5	7.2
			Same as 300K	

ENCLOSURES AND TEMPERATURE SENSORS			
<i>All thermocouples are ungrounded, for optimal performance</i>			
Section "BB"	Description	No. of Sensors	Enclosure
S2	30 to 250°F (-1 to 121°C) Single Pole Thermostat	0	NEMA 1
SJ	J-Type Thermocouple in Thermowell	1	NEMA 1
SL	Dual J-Type Thermocouple in Thermowell	1 Probe, 2 Sets of Wires	NEMA 1
SK	K-Type Thermocouple in Thermowell	1	NEMA 1
SM	Dual K-Type Thermocouple in Thermowell	1 Probe, 2 Sets of Wires	NEMA 1
SR	RTD, Single, 3-Wire, 100 Ohm	1	NEMA 1
W0	No Sensor	0	NEMA 4
W2	30 to 250°F (-1 to 121°C) Single Pole Thermostat	0	NEMA 4
W5	60 to 250°F (16 to 121°C) Double Pole Thermostat	0	NEMA 4
WJ	J-Type Thermocouple in Thermowell	1	NEMA 4
WL	Dual J-Type Thermocouple in Thermowell	1 Probe, 2 Sets of Wires	NEMA 4
WK	K-Type Thermocouple in Thermowell	1	NEMA 4
WM	Dual K-Type Thermocouple in Thermowell	1 Probe, 2 Sets of Wires	NEMA 4
WR	RTD, Single, 3-Wire, 100 Ohm	1	NEMA 4
E0	No Sensor	0	NEMA 7
E1	50 to 250°F (10 to 121°C) Single Pole Thermostat	0	NEMA 7
EJ	J-Type Thermocouple in Thermowell	1	NEMA 7
EL	Dual J-Type Thermocouple in Thermowell	1 Probe, 2 Sets of Wires	NEMA 7
EK	K-Type Thermocouple in Thermowell	1	NEMA 7
EM	Dual K-Type Thermocouple in Thermowell	1 Probe, 2 Sets of Wires	NEMA 7
ER	RTD, Single, 3-Wire, 100 Ohm	1	NEMA 7

SNAP ACTION HIGH LIMITS SWITCHES	
<i>Not available with standoff designs</i>	
Section "C"	Switch
0	None
1	Manual Reset, 260°F (127°C)
2	Automatic Reset, 500°F (260°C)

METRIC MOUNTING HOLES	
<i>Place an "M" In section D if metric mounting holes are required. If standard Imperial mounting holes are desired, section D can be left blank</i>	
Section "D"	Metric Mounting Holes
M	M8 X 1.25 Metric Tapped Mounting Holes

VALUE ADDED OPTIONS FOR FLOW-TUBES	
<i>If you need electropolished or passivated flow-tubes, add these letters to the end of your part number. For both, indicate "EP-P"</i>	
PN Adder	Additional Service
P	Passivation: To Clean Flow-Tube ID (Uses a Diluted Nitric Acid Flush)
EP	Electropolished Tube ID: Ra Value: 10 Micro-Inches (.254 Micro-Meters)

ACCESSORIES	
<i>These PNs are totally separate from the PNs for the heater</i>	
Part	Component
274-55-6-5	Compression Fittings (High Pressure), Pair (Shipped Loose)
307-0-11-1	Insulation Jacket, Maximum Temperature 400°F (204°C)
307-0-21-1	Insulation Jacket, Maximum Temperature 986°F (530°C)

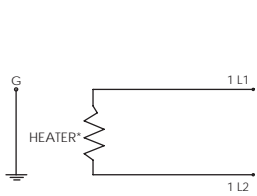

SINGLE PHASE CIRCUIT

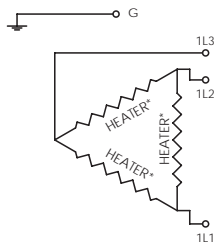

THREE-PHASE DELTA CIRCUIT

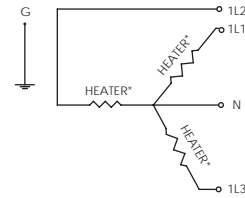

THREE-PHASE WYE CIRCUIT

CAST-X 2000 Available Circuit Types

The CAST-X 2000 is manufactured with these types of circuit configurations.

*Wiring schematic only shows heater elements. Refer to I&M Manual for further details on wiring of snap-action switches and thermostats (if applicable).



NEMA 1 ENCLOSURE WITH THERMOSTAT



NEMA 4 WITH THERMOSTAT INSIDE ENCLOSURE



NEMA 7 ENCLOSURE WITH THERMOSTAT

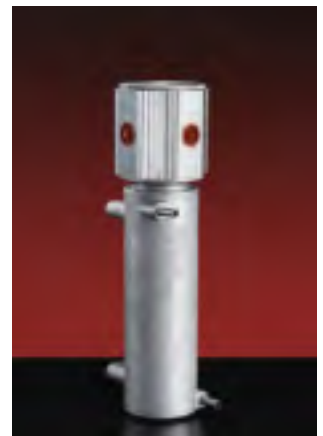

NEMA 7 ENCLOSURE NO THERMOSTAT



SOUTHEAST THERMAL SYSTEMS

WWW.SETHERMAL.COM

RFQ@SETHERMAL.COM

PHONE: 704-399-4248