

CAST-X 2500

Circulation Heater

The CAST-X 2500 is our most compact dual-tube model, a powerful and versatile mid-sized heater.



Designed and manufactured by Cast Aluminum Solutions (CAS), CAST-X Circulation Heaters are engineered using the latest thermal modeling and finite element analysis technology. CAST-X heaters feature low-watt-density heating elements cast into aluminum bodies which also contain the helical-coiled stainless steel flowpath tubes.

The media is sequestered in these tubes, never touching the heating elements: a critical safety benefit, especially when heating explosive or sensitive media. All CAST-X units are capable of heating liquids and gases alike.

CAST-X heaters are self-draining, for safety and cleanliness. With compact, non-welded bodies, plus NEMA & ATEX enclosures, CAST-X units are small-footprint, high-output heaters that meet the needs of high-purity processes, flammable operations, and your most critical heating applications.

APPLICATIONS:

- Paint, Solvent & Petrochem Heating
- Glycol & Heat-Transfer System Use
- Food & Beverage Pasteurization
- Industrial Gas Heating & Air Separation
- Steam Generation
- Laboratory & Analytical Applications
- Urethane / Foam System Heating

SPECIFICATIONS:

- Power:
 - 2.5 kW Total to 15 kW Total
 - Voltage Range: 208 - 480V
 - Max Line Current: 30 A per circuit
 - Tubing:
 - .625" OD (5/8") (15.9 mm)
 - .065" Wall (1.7 mm)
 - Overall Process Tube Length: 130" (3302 mm) each
 - 316L Stainless Steel (standard)
 - Inconel (optional upgrade)
 - Passivated or Electro-Polished (optional upgrades)
 - Max Pressure: 4000 psi (275 bar)
 - Enclosures:
 - NEMA 1 (general-purpose/dust-proof)
 - NEMA 4 (moisture-resistant)
 - NEMA 7 (explosion-proof)
 - ATEX (explosion-proof)
 - Max Working Temperatures:
 - NEMA 1 (dust-proof/general-purpose): 662°F (350°C)
 - NEMA 4 (moisture-resistant): 572°F (300°C)
 - NEMA 7 (explosion-proof): 482°F (250°C)
 - ATEX (explosion-proof): 482°F (250°C)
- Published temperatures are for housing at 12 o'clock position; higher temps may be possible at 6 o'clock position. See factory for details.
- Sensors:
 - K or J Type Thermocouples Standard
 - Snap-Action High-Limit Thermostat
 - Process and High-Limit Thermocouples
 - Available Accessories:
 - Insulating Jackets
 - Compression Fittings

FEATURES & BENEFITS:

- SS 316L Fluid Path is Separate from Heating Elements (allows safe heating of sensitive materials and prevents contamination)
- Very Compact Design: Replaces Much Larger Heaters
- Self-Draining, Low-Maintenance Design
- Non-Welded Body & Cast-In Heaters (for long heater life)
- Wide Application Compatibility (including high pressure)
- Operable in Single-Tube or Dual-Tube Mode
- Dual Tube Mode Can Run in Series or Parallel

CAST-X 2500 Circulation Heater

GENERAL-PURPOSE (NEMA 1) ENCLOSURE

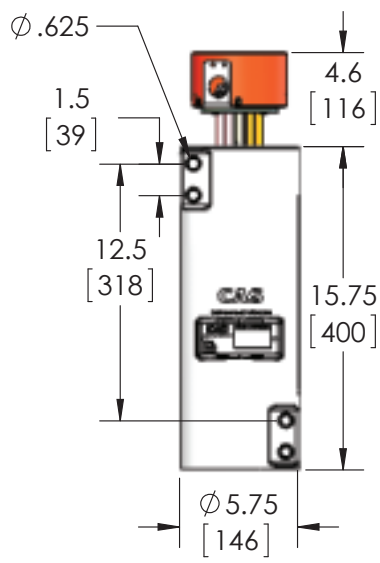

MOISTURE-RESISTANT (NEMA 4) ENCLOSURE

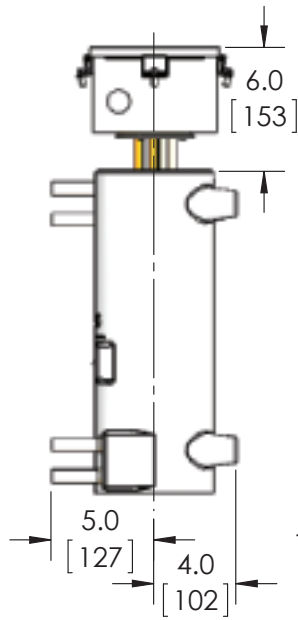

EXPLOSION-PROOF (NEMA 7) ENCLOSURE

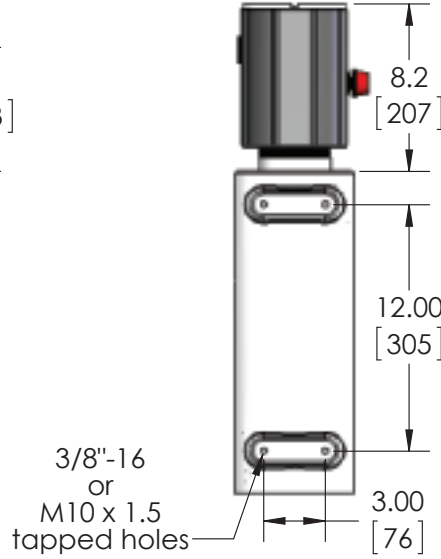

EXPLOSION-PROOF (ATEX) ENCLOSURE

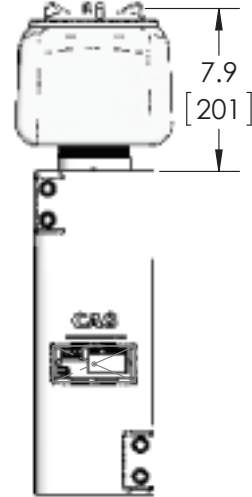

CAST-X2500 Heating Profile: Delta-T Water

(Process Fluid = Water @ 42°F / 5.6°C Inlet Temp, Single Pass Using One Tube, 100% Power, Set Point 752°F / 400°C)

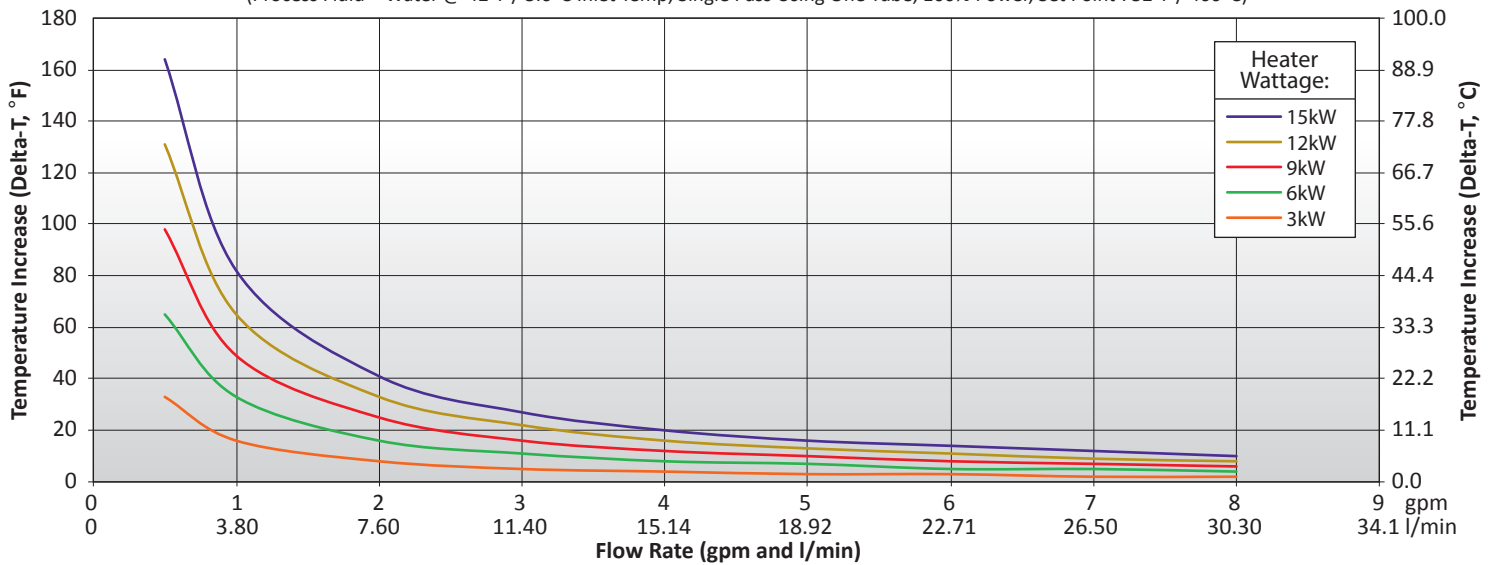

CAST-X 2500 Pressure Drop Profile: Delta-P Water

(Process Fluid = Water. Change in Pressure from Inlet to Outlet, Single Pass Using One Tube)

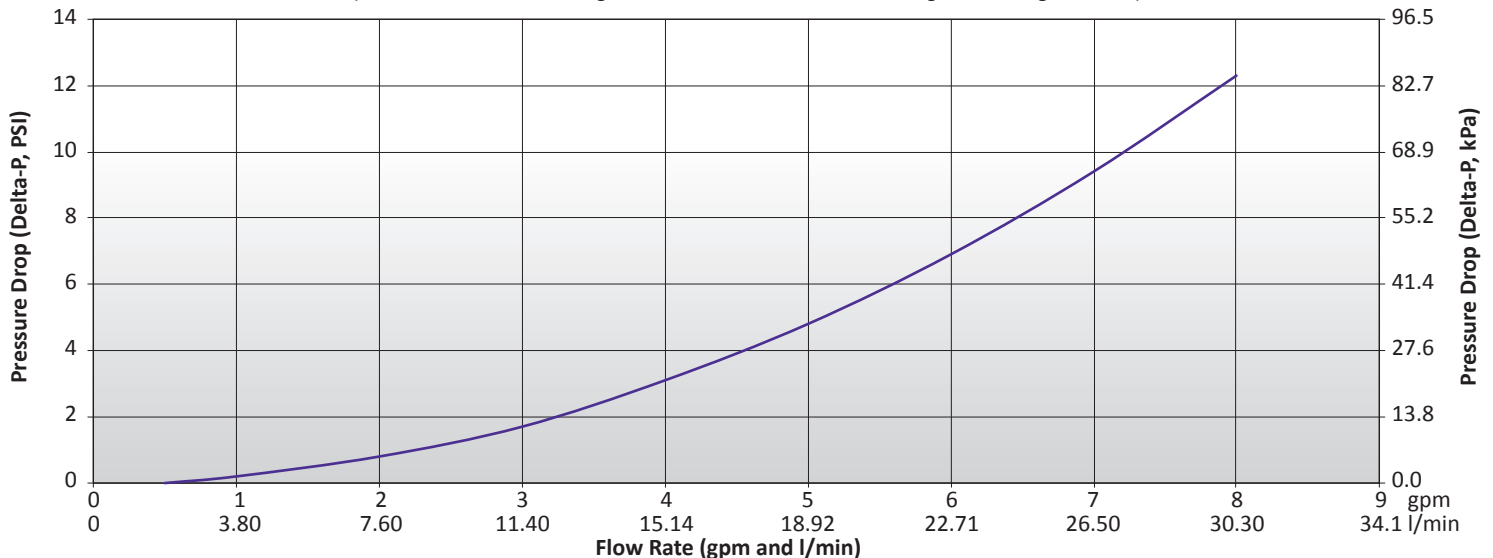



NEMA 1 ENCLOSURE



NEMA 4 ENCLOSURE



NEMA 7 ENCLOSURE



ATEX ENCLOSURE



INSULATING JACKET

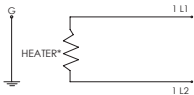

SINGLE PHASE
CIRCUIT

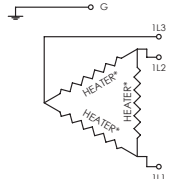

THREE-PHASE
DELTA CIRCUIT

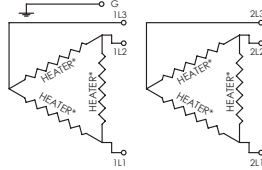

TWO THREE-PHASE
DELTA CIRCUITS

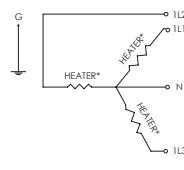

THREE-PHASE
WYE CIRCUIT

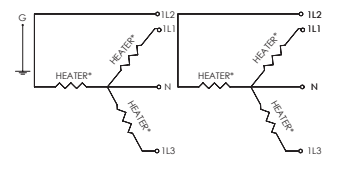

TWO THREE-PHASE
WYE CIRCUITS

CAST-X 2500 Available Circuit Types

The CAST-X 2500 is manufactured with these types of circuit configurations.

*Wiring schematic only shows heater elements. Refer to I&M Manual for further details on wiring of snap-action switches and thermostats (if applicable).

CAST-X 2500 Heating Profile: Delta-T Air

(Process Fluid = Air @ 100 psi (689 kPa), 70.7°F / 21.5°C, Single Pass Using One Tube, Set Point 752°F / 400°C)

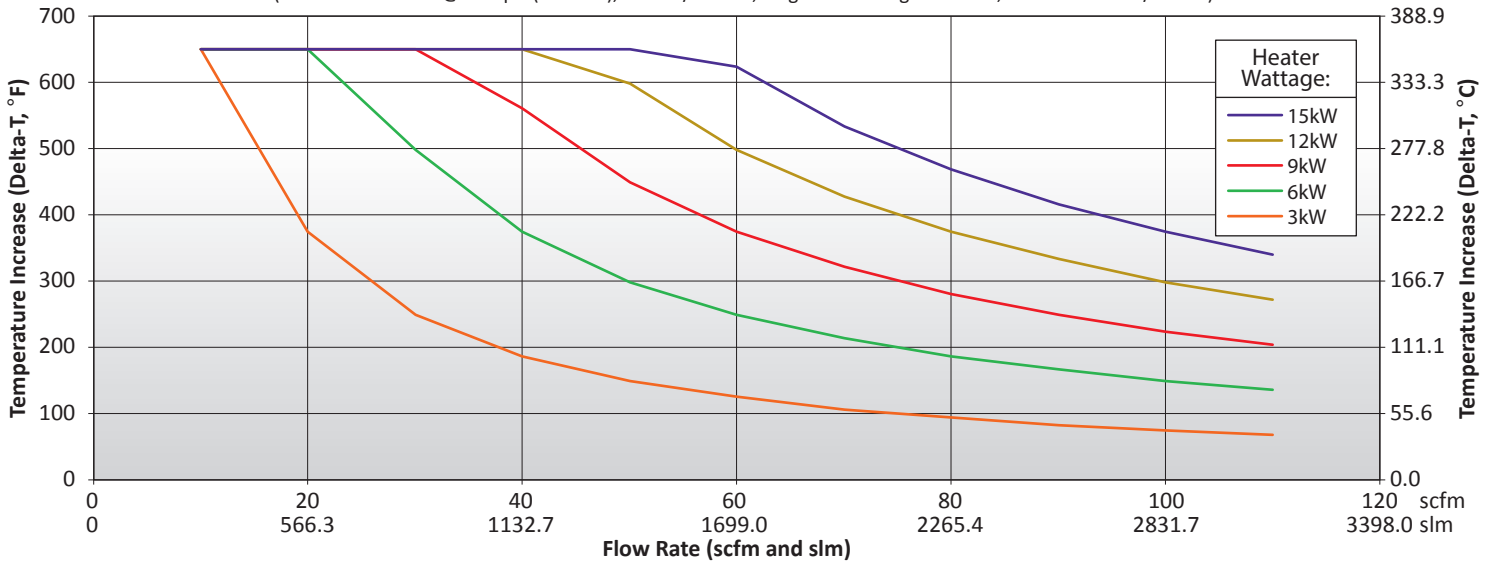

CAST-X 2500 Heating Profile: Delta-P Air

(Process Fluid = Air @ 100 psi (689 kPa), 70.7°F / 21.5°C, Single Pass Using One Tube, Set Point 752°F / 400°C)

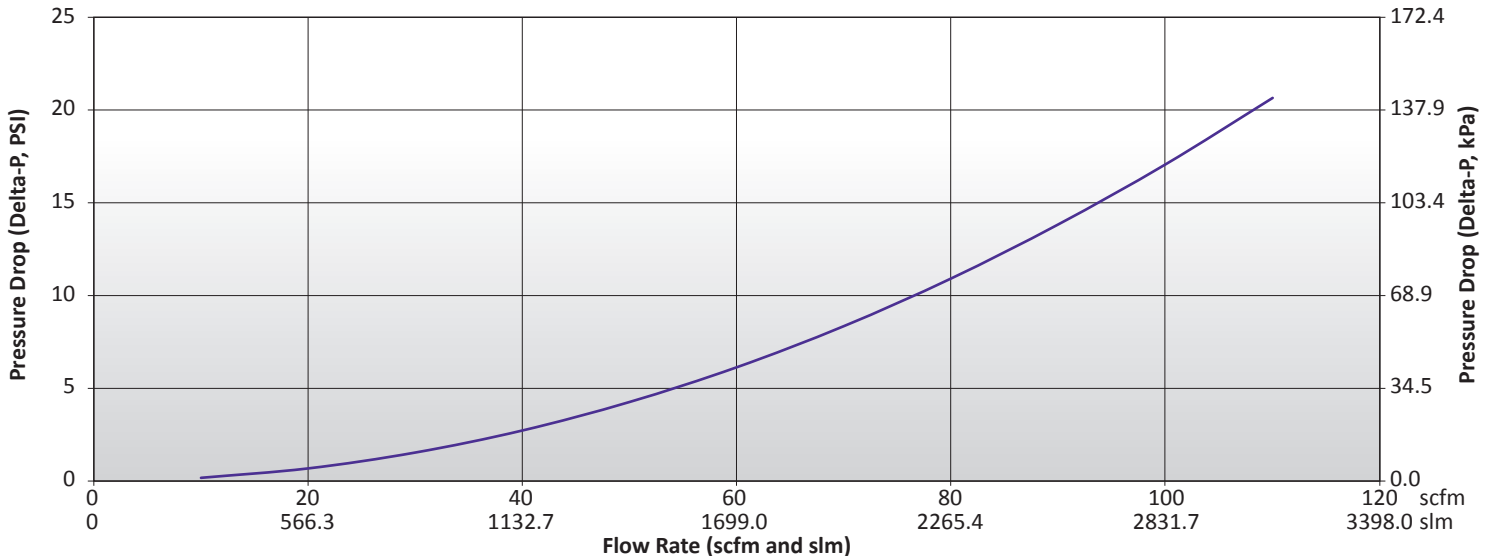

BX25-AAA-BB-CDDEF

AAA = VOLTS, POWER, CIRCUIT TYPE

BB = ENCLOSURES & THERMOSTAT

C = HIGH LIMIT SWITCH

D = THERMOCOUPLES

E = TUBING

F = MACHINING

"AAA" Section

The first step in building a CAST-X 2500 part number is determining the volt, watt and circuit configuration. Select the "AAA" number (far left column) that best matches your specifications.

VOLTAGE, POWER, CIRCUIT TYPE				
Volts refers to line volts (V _L). Amps refers to line current (I _L).				
Section "AAA"	Circuit Type	Volts (V)	Watts (kW)	Amps (A) (per circuit)
012	THREE-PHASE WYE	480	N/A	
		415	14.8	20.7
		400	13.8	19.9
		380	12.4	18.9
		240	5.0	12.0
		208	3.7	10.4
021	THREE-PHASE DELTA	480	15.0	18.0
		415	11.2	15.6
		400	10.4	15.0
		380	9.4	14.3
		240	3.7	9.0
		208	2.8	7.8
022	THREE-PHASE WYE	575	7.2	7.2
		480	5.0	6.0
		415	3.7	5.2
		400	3.4	5.0
		380	3.1	4.8
		240	1.2	3.0
		230	1.1	2.9
		220	1.0	2.0
023	SINGLE PHASE	415	11.2	27.0
		400	10.4	26.0
		380	9.4	24.7
		240	3.7	15.6
		230	3.4	15.0
		208	2.8	13.5
031	THREE-PHASE DELTA	240	7.2	17.3
		208	5.4	15.0
032	THREE-PHASE WYE	480	9.6	11.6
		415	7.2	10.0
		400	6.7	9.6
		380	6.0	9.1
		240	2.4	5.8
033	SINGLE PHASE	240	7.2	30.0
		230	6.6	28.8
		208	5.4	26.0
041	THREE-PHASE DELTA	240	10.7	25.7
		208	8.0	22.2
042	THREE-PHASE WYE	480	14.2	17.1
		415	10.6	14.8
		400	9.9	14.3
		380	8.9	13.5
		240	3.6	8.6
		208	2.7	7.4

BX25-AAA-BB-CDDEF

AAA = VOLTS, POWER, CIRCUIT TYPE

BB = ENCLOSURES & THERMOSTAT

C = HIGH LIMIT SWITCH

D = THERMOCOUPLES

E = TUBING

F = MACHINING

Section "AAA"	Circuit Type	Volts (V)	Watts (kW)	Amps (A) (per circuit)
051	THREE-PHASE DELTA	415	12.0	16.6
		400	11.1	16.0
		380	10.0	15.2
		240	4.0	9.6
		208	3.0	8.3
052	THREE-PHASE WYE	575	7.6	7.7
		480	5.3	6.4
		415	4.0	5.6
		400	3.7	5.4
		380	3.3	5.1
		240	1.3	3.2
		230	1.2	3.1
		220	1.1	2.9
053	SINGLE PHASE	415	12.0	28.8
		400	11.1	27.8
		380	10.0	26.4
		347	8.3	24.1
		240	4.0	16.7
		230	3.6	16.0
		208	3.0	14.4
061	THREE-PHASE DELTA	480	4.0	4.8
		415	3.0	4.2
		400	2.8	4.0
		380	2.5	3.8
		240	1.0	2.4
		230	0.9	2.3
		220	0.8	2.2
063	SINGLE PHASE	480	4.0	8.3
		415	3.0	7.2
		400	2.8	6.9
		380	2.5	6.6
		347	2.1	6.0
		240	1.0	4.2
		230	0.9	4.0
		220	0.8	3.8
		208	0.7	3.6

ENCLOSURE AND THERMOSTAT

The first digit corresponds to the following: 1. Standoff mounting required 2. Pipe nipple mounting required

Designation "BB"	Thermostat	Enclosure
11	NO THERMOSTAT	NEMA 1
12	NO THERMOSTAT	NEMA 4
21	NO THERMOSTAT	NEMA 7
22	32° - 250°F (0° - 121°C) THERMOSTAT	NEMA 7
23	0° - 100°F (-17° - 38°C) THERMOSTAT	NEMA 7
24	NO THERMOSTAT	ATEX
25	DOUBLE POLE SINGLE THROW (DPST) THERMOSTAT	ATEX

BX25-AAA-BB-CDDEF

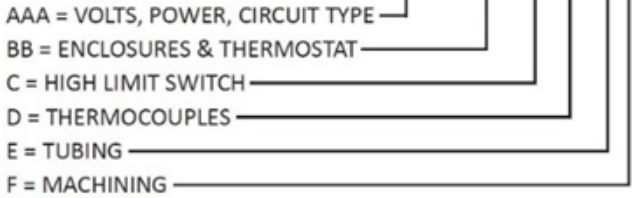

SNAP ACTION HIGH LIMITS SWITCHES

Only heaters with NEMA 7 or ATEX enclosures can accommodate high limit switches: NEMA 1 & 4 cannot.

Designation "C"	Switch
0	NONE
1	AUTO RESET, 200°F (93°C)
2	AUTO RESET, 250°F (121°C)
3	AUTO RESET, 425°F (218°C)
4	AUTO RESET, 500°F (260°C)
5	MANUAL RESET, 260°F (126°C)
6	MANUAL RESET, 185°F (85°C)
7	MANUAL RESET, 150°F (65°C)
8	MANUAL RESET, 260°F (126°C) WITH TEFLON LEADS

"BB" to "F" Sections

After selecting your AAA number, use the charts on this page to select your BB, C, D, E and F designations.

(always selecting your number from the far left column)

THERMOCOUPLES

All thermocouples are ungrounded, for optimal performance

Designation "DD"	Description
0	NONE
1	SINGLE J-TYPE THERMOCOUPLE IN THERMOWELL
2	DUAL J-TYPE THERMOCOUPLES IN THERMOWELL
3	SINGLE K-TYPE THERMOCOUPLE IN THERMOWELL
4	DUAL K-TYPE THERMOCOUPLES IN THERMOWELL

NOTE: The part number has two "D" designations because the unit has two thermowells.
 Always put the lowest designation number first in the part number to avoid duplicate configurations.
 e.g. BX25-xxx-xx-x 1 2 x instead of BX25-xxx-xx-x 2 1 x

TUBING

Option 1 is the standard option (dual 316L SS)

Designation "E"	Tube Description	Number of Tubes
1	5/8" (15.9 mm) OD X .065" (1.65 mm) WALL, 316L SS SEAMLESS (STANDARD OPTION)	2
2	5/8" (15.9 mm) OD X .065" (1.65 mm) WALL, 316L SS SEAMLESS, ELECTROPOLISHED	2
3	5/8" (15.9 mm) OD X .065" (1.65 mm) WALL, 316L SS SEAMLESS, PASSIVATED	2
4	5/8" (15.9 mm) OD X .065" (1.65 mm) WALL, 316L SS SEAMLESS	1
5	5/8" (15.9 mm) OD X .065" (1.65 mm) WALL, 316L SS SEAMLESS, ELECTROPOLISHED	1
6	5/8" (15.9 mm) OD X .065" (1.65 mm) WALL, 316L S.S. SEAMLESS, PASSIVATED	1

MACHINING

Designation "F"	Mounting Hole Description
1	STANDARD 3/8"-16 MOUNTING HOLES
2	STANDARD M10 X 1.5 MOUNTING HOLES

CUSTOM DESIGNS & COMPONENTS

CAS offers several options for special tubes, sensors, and finishes.
 For these options, please call a CAS Representative for a quote.

Options	
SPECIAL ALLOY TUBES	SPECIAL HIGH-LIMIT SWITCHES OR RTDs
THICK WALL TUBES	NPT FITTINGS

ACCESSORIES

Part Number	Description
274-55-6-8	TUBE UNION COMPRESSION FITTING (5/8" / .625 INCH) / PAIR (SHIPPED LOOSE)
307-0-22-1	INSULATING JACKET: TEMP. LIMIT: 986°F / 530°C

Need Assistance ?

The STS Team is ready and available to help you work through part number configurations, provide engineering advice, and ensure customers purchase the heater most appropriate for their particular application.

Contact STS Directly:
 Main Tel: 704-399-4248
 RFQ@sethermal.com
 www.sethermal.com