

# High-Temperature Circulation Heaters

New Product  
Preview

CAST-X HT

**TEMPERATURES  
UP TO  
600°C**



Cast Aluminum Solutions serves semiconductor manufacturers with precision-engineered heated products, including platens, circulation heaters and custom-designed thermal transfer components.

CAS technicians and engineers work closely with customers. Some see our team as an extension of their engineering department. The CAS Team understands your processes, needs and challenges. We leverage this insight to develop innovative products that help you run more efficiently and produce higher-quality end products.

These are the dynamics behind the new "CAST-X HT" line of high temperature circulation heaters, capable of achieving temperatures up to 1112°F (600°C).

Using the proven CAST-X design as a baseline, the HT line features a bronze body with the elements and tube cast-in. Like all CAST-X heaters, the fluid or gas never contacts the heating elements, which reduces contamination and improves safety and reliability.

## FEATURES:

- Indirect Heating (fluid/gas never contacts heating elements)
- **Operating Temperatures to 1112°F (600°C)**
- Moisture Resistant "Stand-Off" Enclosures
- Optional Insulating Jackets
- Optional Thermocouple Sensors
- Self-Draining
- Available in 3 Sizes
- Variety of Volt / Watt Options
- Space-Saving Compact Footprint
- Non-Welded Design
- Compatible with High-Pressure Applications

## APPLICATIONS:

- Dry Etch & OLED Applications
- Multi-Stage Heating
- Steam Generation & Vaporization
- High-Temp Wet Bench Processes
- Nitrogen Heating

# High-Temperature Circulation Heaters

## CAST-X 500 HT



CAST-X 500 HT Heating Profile  
Air, 70°F, 100 psi at Inlet, 1500W

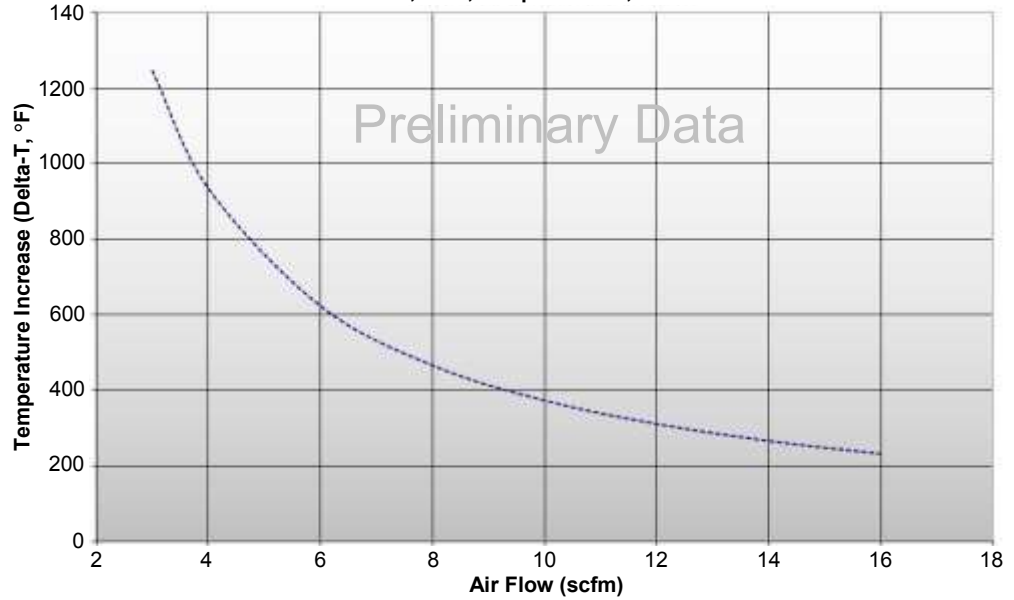

## CAST-X 1000 HT



CAST-X 1000 HT Heating Profile  
Air, 70°F, 100 psi at Inlet, 3kW

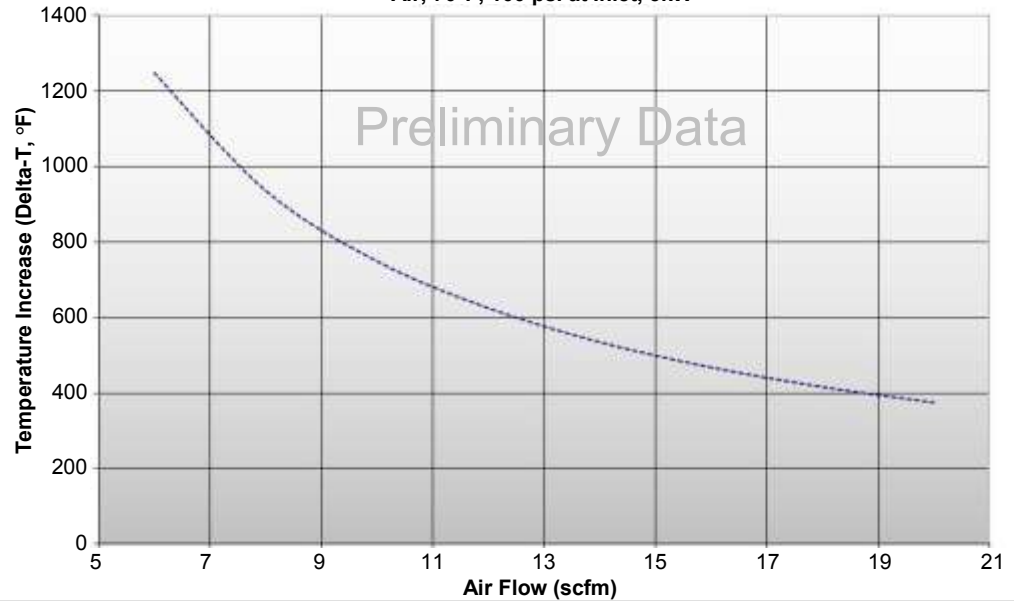

## CAST-X 2000 HT



CAST-X 2000 HT Heating Profile  
Air, 70°F, 100 psi at Inlet, 6kW

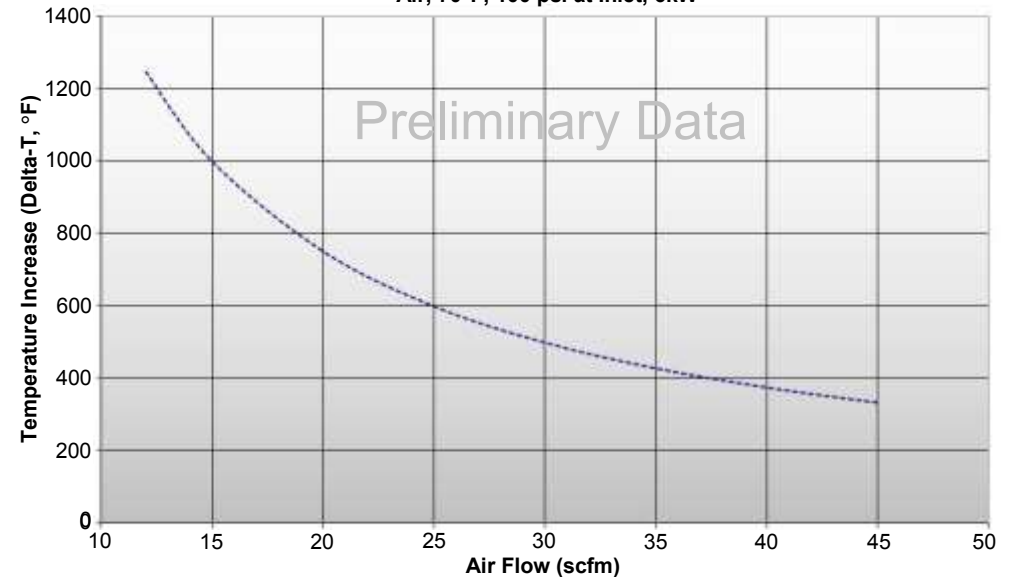

# for Critical Semiconductor Applications

CAST-X 500 HT Pressure Drop Profile  
Air, 70°F, 100 psi at Inlet

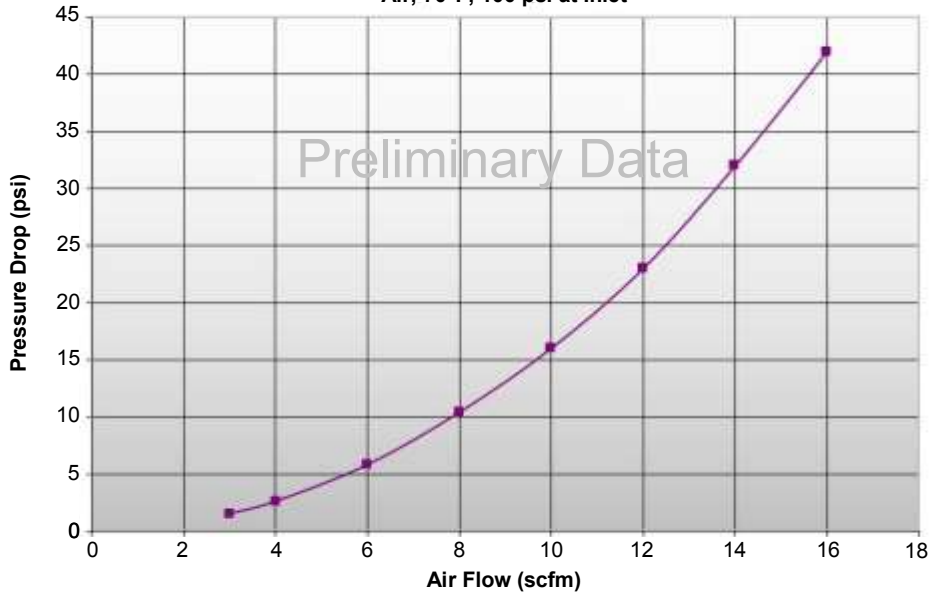

*The CAST-X 500 HT delivers unprecedented heat for such a small unit. Although compact, it is practical for a number of applications.*

CAST-X 1000 HT Pressure Drop Profile  
Air, 70°F, 100 psi at Inlet

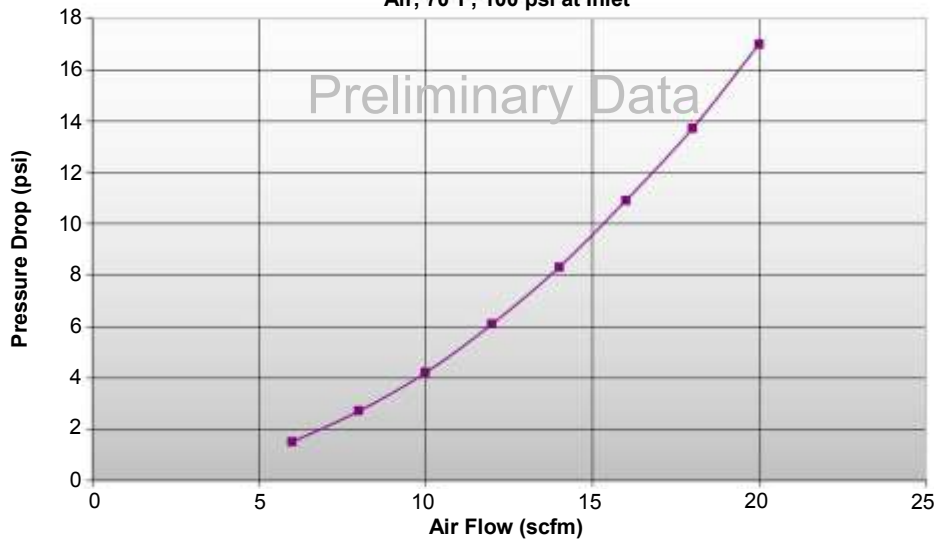

*CAST-X 1000 HT has a tall standoff for the housing, protecting electronic components and ensuring worry-free operation.*

CAST-X 2000 HT Pressure Drop Profile  
Air, 70°F, 100 psi at Inlet

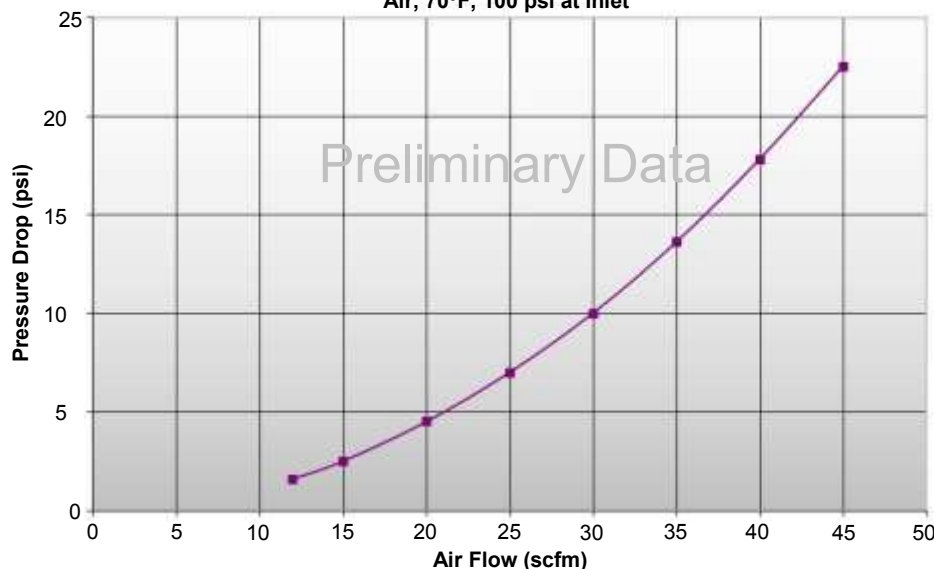

*CAST-X 2000 HT is our largest high-temp model, suitable for higher-output applications. All models are available with insulating jackets.*

# Thermal Solutions to Fit Your Exact Specifications

## CAST-X 500 HT

MAX PRESSURE: 1400 psi [96 bar]  
at 1000°F [537°C]

FLOWPATH TUBE:  
1/4" [6.35 mm] OD  
0.028" [0.710 mm] wall

HEATER TERMINATIONS AVAILABLE:

- Stainless Steel Hose
- Stainless Steel Braid

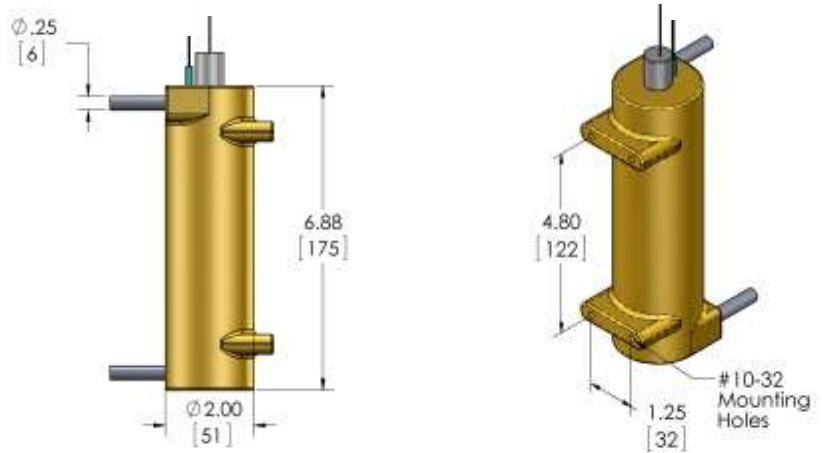

## CAST-X 1000 HT

MAX PRESSURE: 1100 psi [75 bar]  
at 1000°F [537°C]

FLOWPATH TUBE:  
5/16" [7.94 mm] OD  
0.028" [0.710 mm] wall

ENCLOSURES AVAILABLE:

- Moisture-Resistant Enclosure
- Dust-Proof Enclosure

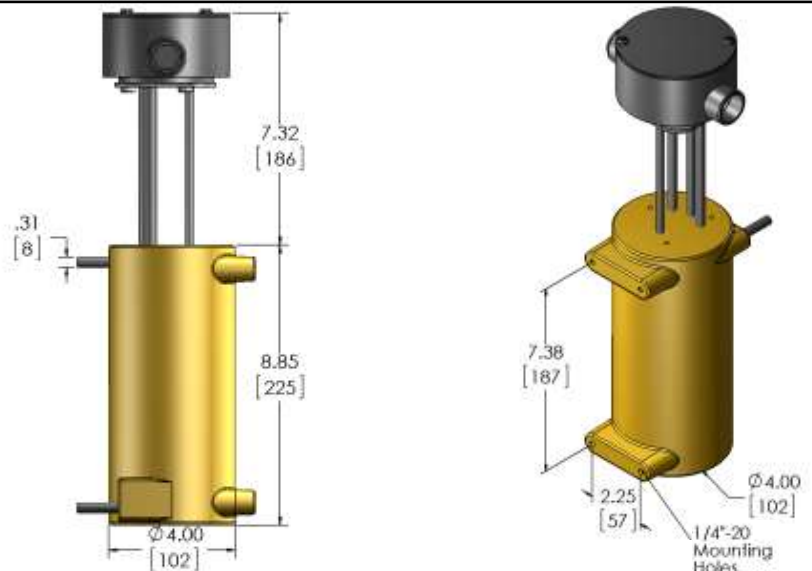

## CAST-X 2000 HT

MAX PRESSURE: 1785 psi [123 bar]  
at 1000°F [537°C]

FLOWPATH TUBE:  
1/2" [12.7 mm] OD  
0.065" [1.650 mm] wall

ENCLOSURES AVAILABLE:

- Moisture-Resistant Enclosure
- Dust-Proof Enclosure

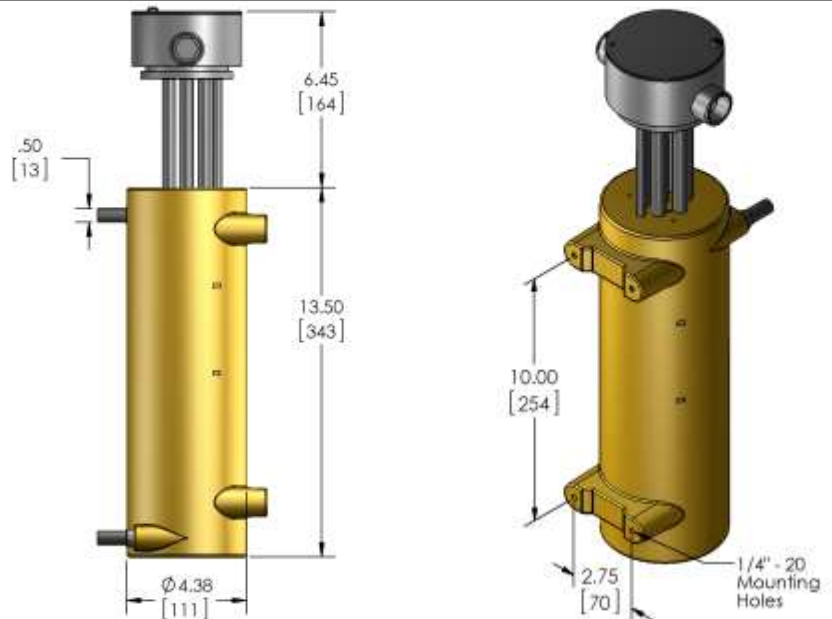

Primary Measurements in Inches  
Metric in [Brackets]

Cast Aluminum Solutions utilizes state-of-the-industry engineering & manufacturing processes to deliver thermal solutions that are well-designed, thoroughly-tested and delivered to your precise specifications. We work closely with our customers to devise practical solutions to complex issues. Speak to a CAS representative to discuss how we can assist with achieving your goals for better processing results and higher-quality end products.



**SOUTHEAST  
THERMAL SYSTEMS**

WWW.SETHERMAL.COM

RFQ@SEETHERMAL.COM

PHONE: 704-399-4248

**Southeast Thermal Systems LLC**  
DENVER, NC (USA) Tel: 704-399-4248  
www.sethermal.com.com  
rfq@sethermal.com